

# Next Generation IoT Networks Based on Wireless Sensor Networks

Dr. Prem Chand Jain, LF-IAFI, FIETE

Ex-Professor, Department of Electrical Engineering, School of Engineering, Shiv Nadar University, Greater Noida UP 201314  
premchandjn@gmail.com

---

**Abstract -- The Internet of Things (IoT) represents a significant technological advancement, poised to profoundly impact various aspects of society and the global economy. By integrating physical objects with network connectivity, IoT enables these objects to collect and exchange data, which has far-reaching implications for improving efficiency, resource distribution, and quality of life. The IoT, powered by wireless sensor networks (WSN), holds the promise of transforming how we interact with the world around us. By leveraging the capabilities of IoT to sense, collect, transmit, analyze, and distribute data, humanity can tackle some of its pressing challenges. From bridging socio-economic gaps to optimizing resource distribution and enhancing our understanding of the environment, IoT offers the potential for a more equitable and sustainable future. As technology continues to evolve, the possibilities for IoT applications will expand, driving innovation and progress across multiple domains. This paper discusses the next generation IoT network based on WSN, its challenges and applications.**

*Keywords: IoT, WSN, M2M, LPWAN, 5G, RedCap, NTN*

## I. INTRODUCTION

THE concept of ubiquity in IoT implies that technology can be available anywhere, anytime, by anyone, and for anything. This means that the future of the Internet will not just connect people and data but also every conceivable object. As a result, while there are currently billions of active Internet users, the number of connected objects could reach hundreds of billions. The objects connected to a network could be a refrigerator connected with grocery stores, laundry machine with clothing, or vehicles with stationary and moving objects, and so on. As IoT continues to develop, traditional dedicated devices like computers may become less prominent. Instead, everyday objects will become intelligent and networked, capable of detecting and monitoring changes in their physical status through sensors in real-time. The integration of IoT with wireless sensor networks (WSN) is revolutionizing the way we interact with the world. By enabling objects to become active Internet users, IoT expands the scope of connectivity beyond traditional devices like laptops, mobile phones, etc. This transformation promises significant benefits in various fields, from environmental monitoring and disaster prevention to healthcare and smart homes. However, it also presents challenges such as security, scalability, and energy efficiency, which need to be addressed to fully realize the potential of IoT based WSN.

In WSN, the sensor nodes collect and transmit information about their surrounding environment. The sensor nodes are often equipped with various types of sensors to monitor different parameters. The sink node collects information from group of sensor nodes and facilitates communication with a central server or cloud, ensuring efficient data aggregation and transmission. The software is essential for collecting, processing, and analyzing large volumes of data generated by the sensor nodes. This involves algorithms and protocols for data aggregation to combine data from multiple sensor nodes to reduce redundancy and enhance the data quality, routing which efficiently directs the data packets from sensor nodes to the sink node or gateway, ensure reliable and secure data transfer, and analyze the collected data to extract useful insights and facilitate decision making.

In the recent years, IoT based WSN have attracted a lot of interest. In this paper, section 2 and 3 introduce WSN and IoT respectively. Section 4 describes various types of communication protocols including 5G and beyond technologies used in IoT with respect to data rates and the coverage. Section 5 evaluates various types of use cases and IoT applications. Finally section 6 concludes the paper.

## II. WIRELESS SENSOR NETWORKS

With advancements in microelectronics, MEMS (Micro-Electro-Mechanical Systems), and wireless communication, WSN have become more efficient, reliable, and cost-effective. Rapid development in MEMS facilitated the creation of miniaturized sensors. The MEMS technology includes various types of sensors like pressure, temperature, humidity, strain gauge, and piezoelectric and capacitive transducers for measuring proximity, position, velocity, acceleration, and vibration. The WSN represent a vital component of the IoT, enabling real-time monitoring and data collection across a wide range of applications. A typical WSN consists of numerous sensor nodes, each comprising sensor elements which measure physical and environmental conditions such as temperature, pressure, light, and humidity; a micro-controller (MCU) acts as the brain of the sensor node, processing data and managing communication; transceiver handles wireless communication between sensor nodes and sink or gateway; and energy source typically batteries or solar power, providing the necessary

power for sensor node operation[1] as shown in Fig. 1.

For large number of sensor nodes in the field, it is necessary to divide the field into number of clusters, each with a sink that communicates directly with server or through a gateway which receives data from various sinks and transmit data to remote server via long range communication standards like 4G, 5G and beyond which support mobility in wide area networks(WAN).

The remote user can also interact with remote server through above networks as shown in Fig. 2. The server stores the data, filters out abnormal values, performs data analysis and mining, determines situational contexts, makes decisions, and forecasts future situations. The ongoing development of energy-efficient designs and energy harvesting technologies promises to further enhance the capabilities and applicability of WSN, paving the way for a more connected and intelligent world.

Though the cost of running cables and installation is avoided in a WSN, but replacing batteries in a large number of sensor nodes is quite complex and costly. The MCUs can enter into sleep or deep sleep modes to minimize the power consumption. If MCU has to wake up once every second, sleep mode could be the best option. If it can stay in low power state longer than one minute or hours at a time, the deep sleep mode can be applied. The aim is to keep overall current consumption of the MCU to an absolute minimum. The real-time clock calendar (RTCC) periodically wakes the MCU to check for tasks. The radio transceiver which consumes maximum power in a sensor node, and managed by micro-controller goes to sleep mode and come back active to reduce the total amount of energy consumption. Future advancements may enable wireless and battery-free sensor networks, reducing costs and increasing flexibility and energy efficiency.

The *Actuators* perform the reverse function of sensors, converting electrical signals into physical actions. They can be classified into three types: information actuators provide visual, audio, or sensory feedback to human users; the gateway actuator manage commands from the sensor control network to other networks; and machine actuators are electro-mechanical devices that interact physically with the external environment.

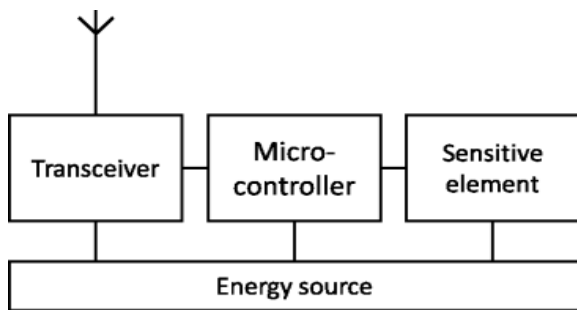

Figure 1. Wireless sensor node.

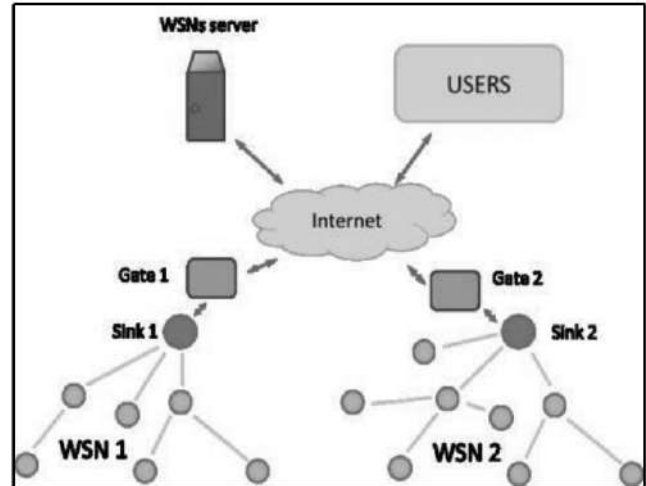

Figure 2. Wireless sensor network

### III. INTERNET OF THINGS

The Internet of Things represents an emerging technology that extends the capabilities of Wireless Sensor Networks (WSN) by incorporating them into a larger, interconnected framework. IoT involves objects from the physical world that can be identified, sensed, actuated, and integrated into communication networks. This integration allows these objects to collect data through embedded sensors, share this data with other devices, and communicate with servers over the Internet [2]. The WSN is a key component of IoT, acting as the data collection backbone. Ordinary objects become IoT devices when embedded with sensors and assigned an IP address. These sensors equipped with micro-controllers and transceivers, collect and transmit data. In a typical WSN set-up, sensor nodes do not connect directly to the Internet. Instead, they relay data to a gateway, which then forwards it to the Internet. This makes WSN a crucial subset of the broader IoT ecosystem. Cisco’s concept of the Internet of Everything (IoE) builds on IoT by incorporating not just things but also humans and data [3]. The IoE includes things- to-things communication, where devices monitor and communicate with each other autonomously. In the human-to-thing communication, the human interact with devices remotely, accessing their status and data.

The human-to-human communication is a traditional communication method using current smart mobile phones devices. The machine-to-machine communication is subset of things-to-things communication. The machine- to-machine (M2M) communication is a key enabler of IoT, allowing machines to exchange data without human intervention. The M2M is an area of growing interest with many business opportunities for mobile operators, system integrators, and solution providers. Unlike current wireless networks optimized for human-to-human communication, M2M focuses on inter-device communication.

The increasing interest in IoT, M2M communication, and WSN has led to the development of new standards focused on IoT applications. The IoT in consumer use cases like smart homes, offices, and buildings, it can lock doors, adjust thermostats, and turn lights on/off from remote locations using smart phone applications. However, IoT in industry and infrastructure use cases like smart metering, smart cities, smart agriculture, smart power grid, smart transportation, or asset management requires low data rates, relatively long ranges with reliability, and long battery life for remotely placed IoT devices.

#### IV. COMMUNICATION PROTOCOLS

To design an efficient communication system for connecting sensor nodes to a gateway, and subsequently the gateway to the cloud, it is important to select appropriate communication protocols based on the required data rates and distances. Here is a structured overview of the communication protocols suited for different ranges and their typical applications. Near Field Communication (NFC) typically Radio frequency identification (RFID) for short-range communication (1-10m) used in identification and tracking the objects. The wireless personal area network (WPAN) typically Bluetooth and ZigBee suitable for low-power, short-range communication (10-100m) are ideal for low-data rate communication, commonly used in home automation and industrial control systems.

Wireless local area network (WLAN) typically WiFi suitable for moderate distances (100-1000m) commonly used for high-speed internet access within homes, offices, and public hot-spots. It can support a range of devices from laptops to IoT devices within a localized area. The LPWAN (Low Power Wide Area Network) technologies [4], both non-cellular (LoRaWAN, Sigfox) and cellular (LTE-M, NB-IoT) are crucial for enabling long-range (1-35kms), low power communication for IoT applications.

The ongoing development and integration of these technologies into the 5G framework will support the exponential growth of IoT devices and applications, providing efficient and cost-effective solutions for remote monitoring and data processing. The Long Range (LoRa) WAN and Sigfox offer very low data transfer rates. The LTE-M (Machine) and Narrow band (NB)-IoT technologies derived from 4G-LTE and adopted by 5G cellular IoT, offers extensive coverage, low power consumption, and the ability to connect many devices [5].

In addition the LTE-M supports higher mobility and lower latency compared to NB-IoT. The advancement in 5G technology have introduced RedCap (Reduced Capacity) [6] and NTN (Non-Terrestrial Networks) [7] offer significant enhancements over LTE-M and NB-IoT. The RedCap offers high data rates, low latency, and extensive coverage for IoT devices, enhancing performance for more data-intensive applications, while NTN ensures comprehensive coverage even

in the most remote and under-served areas where terrestrial networks and optical fiber networks are not available. Together these ensure that IoT devices can operate efficiently and securely anywhere in the world.

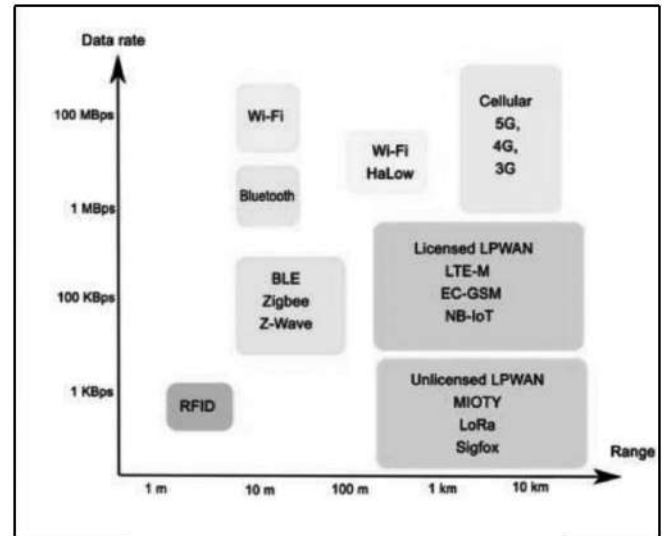

Figure 3. Wireless communication protocols.

#### V. APPLICATIONS

The integration of embedded micro-controllers and wireless interfaces in everyday objects combined with network interfaces allows for advanced monitoring and control. The evolving landscape of communication protocols and the integration of networked devices have paved the way for diverse interactions among people, machines, and objects. The software residing on servers can initiate sequences of events automatically, with or without human intervention.

In machine-to-machine communication, autonomous vehicles communicate to optimize traffic flow and prevent accidents. The vehicles communicate wirelessly to avoid accidents. The enhanced safety and traffic management allows vehicles to coordinate movements to reduce the accidents. An entertainment system that senses and responds to user's movements. This movement can transfer media playback from one room to another based on the user's location. A medicine cabinet fitted with an RFID reader and weight sensors detects when a pill is not removed as prescribed and alerts the patient. It also monitors pill levels and automatically renews prescriptions or schedules the medical appointments. This improves medication adherence and automated healthcare management, reducing burden on patients and healthcare providers. The building can optimize energy savings and indoor air quality. It adjusts climate-control systems based on the number of people entering or leaving the building. It uses oxygen sensors readings to maintain optimal indoor air quality. It enhances the energy efficiency and increases the comfort of occupants.

*a) Retails*

Today every phone sold is equipped with some kind of short range radio communication like NFC (Near Field Communication) specially designed for reading RFID tags. Soon the consumer will no longer need to consult a shop floor reader to know the history of a product. This opens for automated warehouse where the shopping list is transmitted when the customer leaves the house to collect a ready-made shopping bag already checked upon arrival to the warehouse. With the ability of directly reading the tags, the inventory of your belongings may be stored in your mobile phone making insurance claims easier and facilitating the private sales of goods since a centralized registry of things will no longer be needed.

*b) Logistics*

Present day logistics is based on established supply chains from manufacturer to consumer. It is possible to envision that the things in transit from a market place and that a consumer could place a request on the IoT, receive and accept an offer from a thing fulfilling the request.

*c) Pharmaceutical*

Smart biodegradable dust nodes (size of dust particle) embedded inside pills may interact with the intelligent tag on the box allowing the latter to monitor the use and abuse of medicine and inform the pharmacist when new supply is needed. The smart dust in pills could know incompatible drugs.

*d) Food*

Knowing the origin of each food item is essential to ensure that it is not carrying unwanted diseases, and to enable selective recalls of infected items avoiding to waste good food as a safety precaution.

*e) Healthcare*

New efficient diagnostics combined with Nano technology enabled *Lab-on-chip* opens a complete range of novel opportunities for new treatments and prevention of serious diseases. It is an established fact that several serious common illnesses like cancer, cardio-vascular disease, and Alzheimer's disease have genetic components. Thus Lab may test persons at risk providing a sufficiently frequent sampling to allow early detection and improved recovery possibilities. This sort of personal medical equipment will enable the patient to stay longer and safer at home since the equipment itself can alarm the hospital in case of critical situations or the patient can be relieved from the hassle of routine checks when there is nothing wrong. The Tele-medicine may replace costly travel and reduce patient stress.

*f) Smart Buildings*

A lot of energy is consumed by different equipments in the buildings *e.g.* HVAC (Heating, ventilation, AC), lighting, home

and office appliances. For this, temperature nodes are used to react upon variation in room temperature. Actuator nodes are responsible to control subsystem within the building. Presence of sensor can automatically switch-off lighting when employee left his office. Even more energy can be saved when different subsystems cooperate with each other *e.g.* central control unit system can switch-off the office lights. Building automation and control system rely on many sensors and actuators placed at different locations throughout a building. Reducing power consumption of a smart building requires continuous monitoring of various environmental parameters inside and outside the building. The key requirement for an efficient monitoring and controlling is that all sensors and actuators are addressable over the network.

Web application allows defining a set of rules which trigger certain actions based on specified event. A typical rule could be "If the motion sensor in room-A does not detect any movement for five minutes, turn off the lights in room-A and put the PC to standby mode". As the functionality of the device is discovered by the central unit, the effort required to set up monitoring applications for smart building can be significantly reduced. With IoT the lamps or even light bulbs will be addressable and intelligent, and a global house management controller will be able to control every single smart device. Maintaining a comfortable temperature and heating of water are the most energy consuming tasks of the house with huge potentials for energy conservation.

*g) Transport*

In modern cars 30% of the total cost is due to electronic components. With IoT the cars will be able to communicate and autonomously start gathering ambient information. The cars may help the driver to keep the safe distance to the car in- front. Optimal route planning will reduce number of kms driven, and better control systems for the car will make the ride more energy efficient. This will reduce emissions and less pollution. The public transport sector may be radically changed when smart devices and travelers are identifiable. Ticketing based on RFID is already widely available.

*h) Pollution and Disaster Avoidance*

Combining sensory information will allow early warnings and prevention of catastrophes. An open gas valve on a stove may be detected by comparing gas flow measurement with lack of increased temperature in the room. The RFID tags, sensors, actuators will interact with environment in which they are placed. One such example could be an interactive device placed in the human body with the scope of delivery the right medicine at the right place at the right time.

*i) Social and Political Issues*

Much of the public debate will be 'security Vs freedom' and comfort Vs data privacy. If technology of IoT fails for whatever

reason – design faults, material defects, sabotage, over-loading, natural disasters, or crises – it could have a disastrous effect on the economy and society. Even a virus programmed by someone will play a global havoc with selected everyday objects and thus provoke a safety-critical, life-threatening, or even politically explosive situation could have catastrophic consequences. IoT would make us ‘totally dependent on technology and those in powers’ and would mean ‘surrendering all freedom’. In IoT everyday objects equipped with micro-controller electronics cooperate with each other. Just as essential are secure, reliable infrastructure, appropriate economic and legal conditions, and a social consensus on how the new technical opportunities should be used. This represents a substantial task for the future.

## VI. CONCLUSION

The integration of IoT with WSN offers significant potential to enhance efficiency, productivity, and connectivity across various sectors. However, realizing this potential requires addressing challenges related to complexity, security, interoperability, scalability, and energy efficiency. By incorporating self-managing, self-healing, and self-configuring properties, future IoT systems can overcome these challenges and drive the technological revolution forward. The societal and cultural impacts of the hyper-connected world are yet to be fully understood, but the potential benefits are immense, paving the way for a smarter, more connected future. The existing work defined the role of IoT in WSN, challenges, and its applications reviewed in this paper. The IoT is a technological revolution that represents the future of computing and communication, and its development depends on dynamic technical innovation from wireless sensors to nano technology. Miniaturization of devices is taking place amazingly fast.

## REFERENCES

- [1] ITU-T Series Y.2000, “Applications of wireless sensor networks in next generation networks”, ITU- Docu. NGN-A WSN, pp 1-90, 02/2014
- [2] ITU-T Series Y.2060, “Overview of the Internet of Things”, *ITU-Docu.* pp 1-14, 06/2012.
- [3] D. Evans, “The Internet of things: How the next evolution of the Internet is changing everything”, White Paper, <http://www.CISCO.com/go/ibDG>. April, 2011, pp1-11.
- [4] K. Mekki, E. Bajic, F. Chaxel and F. Meyer, “A comparative study of LPWAN technologies for large scale IoT deployment”, *ICT Express*, Dec.2017, pp 1-17.
- [5] U. Raza, P. Kulkarni and M. Sooriyabandara, “Low power wide area networks: An overview”, *IEEE J. Com. Survey, Tutorial*, vol.19, no. 2, 2017, pp 855-873.
- [6] S. Bahen and S, Lu, “Cellular technology evolution for IoT applications in the 5G era: The importance of NR RedCap for 5G-IoT”, White paper, pp 1-13, [www.u-blox.com](http://www.u-blox.com)
- [7] 3GPP TR 38.821, “Solution for NR to support non- terrestrial network”, Re. 16, *Third Generation Partnership Project (3GPP)*, March, 2023.



**Prof. Prem Chand Jain**, FIETE (b. 1 July, 1946), obtained B.E., M.E. (Electronics) from BITS, Pilani in 1968, 1972 respectively, and Ph.D. from the University of Louvain, Belgium in 1979 specializing in video compression using transform coding for digital video broadcasting. Possesses research experience in speech and video compression over 35 years at CEERI, Pilani and HFCL R&D, Gurgaon; Teaching experience in multimedia communication, communication & networks, cellular mobile communications and IoT at C-DAC, Noida and Shiv Nadar University, G. Noida. Published 160 research papers in various international/national journals/conferences. Visited Belgium, Germany, USA, Singapore, Hongkong for PhD, as an Expert, Post Doc., Broadcast Asia, Collaboration with Star TV respectively. Life Fellow/member of IAFI, IETE, BES, CSI. Presently associated with IAFI and TEC in 6G, Broadcasting, and IoT group for standardization.