



Received: 19 January 2024

Source: Annex 5.5 to Document [5D/1776](#)

**Document 5D/62-E**  
**22 January 2024**  
**English only**

**TECHNOLOGY ASPECTS**

## IAFI<sup>1</sup>

### UPDATES TO WORKING DOCUMENT TOWARDS A PRELIMINARY DRAFT NEW RECOMMENDATION ITU-R M.[IMT-2020.UNWANT.BS]

#### **Unwanted emission characteristics of base stations using the terrestrial radio interface of IMT-2020**

At the 44th meeting of Working Party (WP) 5D (Geneva, 12-22 June 2023), Sub-Working Group (SWG) OOBE elevated the preliminary draft revision status of Recommendations [ITU-R M.2070](#) to draft revision. The document is available in Revision 1 to Document [5/136](#).

This contribution proposes updates to the working document of preliminary draft new Recommendation ITU-R M.[IMT-2020.UNWANT.BS] to harmonize with text in the draft revision of Recommendation ITU-R M.2070.

To that end, updates are proposed in the following sections of working document towards a preliminary draft new Recommendation ITU-R M.[IMT-2020.UNWANT.BS]:

- scope
- considering
- noting
- recommends.

The proposed changes are marked in the Attachment below and are highlighted in grey.

#### **WRC-2023, Dubai, United Arab Emirates, 20th November 2023 to 15th December 2023**

WRC-2023 approved the addition of new footnotes identifying the following bands for the terrestrial component of IMT:

- 6 425-7 125 MHz – refer WRC-23 Provision Final Acts, footnotes RR Nos. **5.6A12**, **5.6B12** and **5.6C12**;
- 3 700-3 800 MHz – refer WRC-23 Provision Final Acts, footnote RR No. **5.36A12**.

IAFI propose that this regulatory development be included as part of the proposed updates – see Table 1-2A and Table 1-2B in the Attachment below.

**Attachment:** 1

---

<sup>1</sup> ITU-APT Foundation of India is a sector member of ITU (<https://iafi.in>).

## ATTACHMENT

### WORKING DOCUMENT TOWARDS A PRELIMINARY DRAFT NEW RECOMMENDATION ITU-R M.[IMT-2020.UNWANT.BS]

#### **Unwanted emission characteristics of base stations using the terrestrial radio interface of IMT-2020**

(202X)

*[Editor's note: This document is a compilation of input received to date. The document has not been reviewed and is not agreed by the membership of ITU-R WP 5D.]*

#### **Scope**

This Recommendation provides the unwanted emission characteristics of base stations using radio interfaces for the terrestrial component of IMT-2020. The information in this recommendation on unwanted emissions could also be used as guidance by Administrations. Implementation of unwanted emission characteristics of base stations using radio interfaces for terrestrial component of IMT-2020 specified in any of the bands included in this Recommendation is subject to compliance with the Radio Regulations.

#### **Keywords**

IMT-2020, emission characteristics, out-of-band, unwanted, base station

The ITU Radiocommunication Assembly,

*considering*

- a) that unwanted emissions consist of both spurious and out-of-band (OoB) emissions according to No. **1.146** of the Radio Regulations (RR) and that spurious and OoB emissions are defined in RR Nos **1.145** and **1.144**, respectively;
- b) that limitation of the maximum permitted levels of unwanted emissions of IMT-2020 base stations (BS) is necessary to protect other radio systems and services from interference and to enable coexistence between different technologies;
- c) that too stringent limits may lead to an increase in complexity of IMT-2020 BS;
- d) that every effort should be made to keep limits for unwanted emissions at the lowest possible values taking account of economic factors and technological limitations;
- e) that the harmonization of unwanted emission limits will facilitate global use and access to a global market; however national/regional variations in unwanted emission limits may exist;
- f) that unwanted emission limits are dependent on the transmitter emission characteristics, ITU spurious emission limits and national standards and regulations in addition to depending on services operating in other bands,

*noting*

- a) that IMT-2020 base stations **should** comply with local, regional, and international regulations for out-of-band and spurious emissions relevant to their operations, wherever such regulations apply;
- b) that **in order to reflect the wide applicability of IMT-2020 radio interfaces technologies and to maintain consistency with the technology specifications** the notes and annexes of this

Recommendation – being based on the ongoing work in standardization bodies, may contain material that reflects information related to use of these technologies in bands other than those identified for IMT,

*recommends*

1 that the unwanted emission characteristics of base stations that correspond to the radio interface specifications for the terrestrial component of IMT-2020 should be based on the limits contained in the technology specified in Annexes 1, 2, 3 and X in the bands specified in Tables 1-1A and 1-2A;

2 that the unwanted emission characteristics of IMT-2020 base stations in Annexes 1, 2, 3 and X should apply in the bands specified in Tables 1-1A and 1-2A in Regions and countries in which corresponding bands are identified for IMT in the Radio Regulations\*\*.

Annex 1: “3GPP 5G-SRIT”<sup>2</sup>

Annex 2: “3GPP 5G-RIT”<sup>3</sup>

Annex 3: “5Gi”<sup>4</sup>

Annex X: “DECT-2020 NR - RIT Component”

*[Editor’s note: Annexes 1, 2 and 3 are to be provided by GCS proponents for Recommendation ITU-R M.[IMT-2020.SPECS].*

---

<sup>2</sup> Developed by 3GPP Proponent as “5G, Release 15 and beyond – LTE+NR SRIT”.

<sup>3</sup> Developed by 3GPP Proponent as “5G, Release 15 and beyond – NR RIT”.

<sup>4</sup> Developed by TSDSI as “5Gi RIT”.

## **Annex 1**

### **3GPP 5G-SRIT**

Source: Document [5D/1530](#)

## **Annex 2**

### **3GPP 5G-RIT**

### **3GPP 5G**

The present Annex includes unwanted emission requirements from NR carriers for NR base stations. The requirements shall apply to BS that support NR, or NR with NB-IoT operation in NR in-band.

A NR base station is characterized by the ability of its receiver and transmitter to process only NR carriers or NR carriers with NB-IoT operation in NR in-band.

This Annex is outlined as follows:

- Chapter 1 specifies the frequency ranges and operating bands for which the requirements in the present Annex apply.
- Chapter 2 specifies definitions, symbols and abbreviations.
- Chapter 3 includes the NR BS unwanted emission requirements for BS type 1-C and BS type 1-H.
- Chapter 4 includes the NR BS unwanted emission requirements for BS type 1-O and BS type 2-O.
- Chapter 5 specifies references.

Values specified in the present Annex incorporate test tolerances defined in Recommendation ITU-R M.1545 [4].

## **1 Operating bands**

Requirements throughout the RF specifications are in many cases defined separately for different frequency ranges (FR). The frequency ranges in which NR can operate according to the present version of the specification are identified as described in Table 1-1.

TABLE 1-1  
NR frequency ranges

Frequency range designation		Corresponding frequency range
FR1		698 MHz – 7 125 MHz
FR2	FR2-1	24 250 MHz – 52 600 MHz
	FR2-2	52 600 MHz – 71 000 MHz

The unwanted emission limits defined in the present Annex are for NR BS operating in at least one of the bands in Table 1-2A or Table 1-3A:

*[Editor's Note: If a frequency band in the 3GPP NR operating band covers a larger frequency band then what is identified in the RR and Recommendation ITU-R M.1036, then the IMT identified band is listed in the table for IMT frequency band and the sub-bands that are not IMT identified are listed in the table for non-IMT bands. For example: NR band 41: 2 496-2 690 MHz is treated by listing 2 500-2 690 MHz in the table for IMT bands and 2 496-2 500 MHz is listed under NR band 41 in the table for non-IMT band]*

TABLE 1-2A

**NR operating bands in FR1**

**Frequency bands utilized in E-UTRA and identified for IMT in the RR**

NR operating band number	Uplink (UL) operating band BS receive / UE transmit $F_{UL,low} - F_{UL,high}$	Downlink (DL) operating band BS transmit / UE receive $F_{DL,low} - F_{DL,high}$	Duplex mode	[Footnote(s) Identifying the band, or part thereof, for IMT in various countries/Regions]
n1	1 920 MHz – 1 980 MHz	2 110 MHz – 2 170 MHz	FDD	5.388
n2	1 850 MHz – 1 910 MHz	1 930 MHz – 1 990 MHz	FDD	5.384A, 5.388
n3	1 710 MHz – 1 785 MHz	1 805 MHz – 1 880 MHz	FDD	5.384A
n5	824 MHz – 849 MHz	869 MHz – 894 MHz	FDD	5.317A
n7	2 500 MHz – 2 570 MHz	2 620 MHz – 2 690 MHz	FDD	5.384A
n8	880 MHz – 915 MHz	925 MHz – 960 MHz	FDD	5.317A
n12	699 MHz – 716 MHz	729 MHz – 746 MHz	FDD	5.317A
n13	777 MHz – 787 MHz	746 MHz – 756 MHz	FDD	5.317A
n14	788 MHz – 798 MHz	758 MHz – 768 MHz	FDD	5.317A
n18	815 MHz – 830 MHz	860 MHz – 875 MHz	FDD	5.317A
n20	832 MHz – 862 MHz	791 MHz – 821 MHz	FDD	5.317A
n25	1 850 MHz – 1 915 MHz	1 930 MHz – 1 995 MHz	FDD	5.384A, 5.388
n26	814 MHz – 849 MHz	859 MHz – 894 MHz	FDD	5.317A
n28	703 MHz – 748 MHz	758 MHz – 803 MHz	FDD	5.317A
n29	N/A	717 MHz – 728 MHz	SDL	5.317A
n30	2 305 MHz – 2 315 MHz	2 350 MHz – 2 360 MHz	FDD	5.384A
n34	2 010 MHz – 2 025 MHz	2 010 MHz – 2 025 MHz	TDD	5.388
n38	2 570 MHz – 2 620 MHz	2 570 MHz – 2 620 MHz	TDD	5.384A
n39	1 880 MHz – 1 920 MHz	1 880 MHz – 1 920 MHz	TDD	5.388
n40	2 300 MHz – 2 400 MHz	2 300 MHz – 2 400 MHz	TDD	5.384A
n41	2 500 MHz – 2 690 MHz	2 500 MHz – 2 690 MHz	TDD	5.384A
n48	3 550 MHz – 3 700 MHz	3 550 MHz – 3 700 MHz	TDD	5.430A, 5.431B, 5.433A, 5.434
n50	1 432 MHz – 1 517 MHz	1 432 MHz – 1 517 MHz	TDD	5.341A, 5.341B, 5.341C
n51	1 427 MHz – 1 432 MHz	1 427 MHz – 1 432 MHz	TDD	5.341A, 5.341B, 5.341C
n65	1 920 MHz – 2 010 MHz	2 110 MHz – 2 200 MHz	FDD	5.388
n66	1 710 MHz – 1 780 MHz	2 110 MHz – 2 200 MHz	FDD	5.384A, 5.388
n67	N/A	738 MHz – 758 MHz	SDL	5.317A
n70	1 695 MHz – 1 710 MHz	1 995 MHz – 2 020 MHz	FDD	5.388
n71	663 MHz – 698 MHz	617 MHz – 652 MHz	FDD	5.296A

NR operating band number	Uplink (UL) operating band BS receive / UE transmit $F_{UL,low} - F_{UL,high}$	Downlink (DL) operating band BS transmit / UE receive $F_{DL,low} - F_{DL,high}$	Duplex mode	[Footnote(s) Identifying the band, or part thereof, for IMT in various countries/Regions]
n74	1 427 MHz – 1 470 MHz	1 475 MHz – 1 518 MHz	FDD	5.341A, 5.341B, 5.341C
n75	N/A	1 432 MHz – 1 517 MHz	SDL	5.341A, 5.341B, 5.341C
n76	N/A	1 427 MHz – 1 432 MHz	SDL	5.341A, 5.341B, 5.341C
n77	3 300 MHz – 3 800 MHz	3 300 MHz – 3 800 MHz	TDD	5.429B, 5.529D, 5.429F, 5.430A, 5.431B, 5.432A, 5.432B, 5.433A, 5.434, 5.36A12
n78	3 300 MHz – 3 800 MHz	3 300 MHz – 3 800 MHz	TDD	5.429B, 5.529D, 5.429F, 5.430A, 5.431B, 5.432A, 5.432B, 5.433A, 5.434, 5.36A12
n79	4 800 MHz – 4 990 MHz	4 800 MHz – 4 990 MHz	TDD	5.441A, 5.441B
n80	1 710 MHz – 1 785 MHz	N/A	SUL	5.384A
n81	880 MHz – 915 MHz	N/A	SUL	5.317A
n82	832 MHz – 862 MHz	N/A	SUL	5.317A
n83	703 MHz – 748 MHz	N/A	SUL	5.317A
n84	1 920 MHz – 1 980 MHz	N/A	SUL	5.388
n85	698 MHz – 716 MHz	728 MHz – 746 MHz	FDD	5.317A
n86	1 710 MHz – 1 780 MHz	N/A	SUL	5.384A
n89	824 MHz – 849 MHz	N/A	SUL	5.317A
n90	2 496 MHz – 2 690 MHz	2 496 MHz – 2 690 MHz	TDD	5.384A
n91	832 MHz – 862 MHz	1 427 MHz – 1 432 MHz	FDD <sup>(2)</sup>	5.317A, 5.341A, 5.431B, 5.341C
n92	832 MHz – 862 MHz	1 432 MHz – 1 517 MHz	FDD <sup>(2)</sup>	5.317A, 5.341A, 5.341B, 5.341C, 5.346, 5.346A
n93	880 MHz – 915 MHz	1 427 MHz – 1 432 MHz	FDD <sup>(2)</sup>	5.317A, 5.341A, 5.431B, 5.341C
n94	880 MHz – 915 MHz	1 432 MHz – 1 517 MHz	FDD <sup>(2)</sup>	5.317A, 5.341A, 5.341B, 5.341C, 5.346, 5.346A
n95 <sup>(1)</sup>	2 010 MHz – 2 025 MHz	N/A	SUL	5.388
n96	6 425 MHz – 7 125 MHz	6 425 MHz – 7 125 MHz	TDD	5.6A12, 5.6B12, 5.6C12
n97 <sup>(5)</sup>	2 300 MHz – 2 400 MHz	N/A	SUL	5.384A
n98 <sup>(5)</sup>	1 880 MHz – 1 920 MHz	N/A	SUL	5.384A, 5.388
n101	1 900 MHz – 1 910 MHz	1 900 MHz – 1 910 MHz	TDD	5.388
n104	6 425 MHz – 7 125 MHz	6 425 MHz – 7 125 MHz	TDD	5.6A12, 5.6B12, 5.6C12

<sup>(1)</sup> This band is applicable in China only.

<sup>(2)</sup> Variable duplex operation does not enable dynamic variable duplex configuration by the network and is used such that DL and UL frequency ranges are supported independently in any valid frequency range for the band.

<sup>(3)</sup> This band is restricted to operation with shared spectrum channel access as defined in TS 37.213 [4].

<sup>(4)</sup> This band is applicable only in countries/regions designating this band for shared-spectrum access use subject to country-specific conditions.

<sup>(5)</sup> The requirements for this band are applicable only where no other NR or E-UTRA TDD operating band(s) are used within the frequency range of this band in the same geographical area. For scenarios where other NR or E-UTRA TDD operating band(s) are used within the frequency range of this band in the same geographical area, special co-existence requirements may apply that are not covered by the 3GPP specifications.

<sup>(6)</sup> UL operation is restricted to 1 627.5-1 637.5 MHz and 1 646.5-1 656.5 MHz per FCC Order DA 20-48.

<sup>(7)</sup> DL operation is restricted to 1 526-1536 MHz frequency range. UL operation is restricted to 1 627.5-1 637.5 MHz and 1 646.5-1 656.5 MHz per FCC Order DA 20-48.

<sup>(8)</sup> This band is applicable only in countries/regions designating this band for IMT licensed operation in accordance with RCC Recommendation 1/21.

TABLE 1-2B

**NR operating bands in FR1**

**Frequency bands utilized in E-UTRA and NOT identified for IMT in the RR**

NR operating band number	Uplink (UL) operating band BS receive / UE transmit $F_{UL,low} - F_{UL,high}$	Downlink (DL) operating band BS transmit / UE receive $F_{DL,low} - F_{DL,high}$	Duplex mode	[Footnote(s) Identifying the band, or part thereof, for IMT in various countries/Regions]
n24 <sup>(7)</sup>	1 626.5 MHz – 1 660.5 MHz	1 525 MHz – 1 559 MHz	FDD	Not Identified for IMT in RR
n41	2 496 MHz – 2 500 MHz	2 496 MHz – 2 500 MHz	TDD	Not Identified for IMT in RR
n46	5 150 MHz – 5 925 MHz	5 150 MHz – 5 925 MHz	TDD <sup>(3)</sup>	Not Identified for IMT in RR
n53	2 483.5 MHz – 2 495 MHz	2 483.5 MHz – 2 495 MHz	TDD	Not Identified for IMT in RR
n77	3 800 MHz – 4 200 MHz	3 800 MHz – 4 200 MHz	TDD	Not Identified for IMT in RR
n79	4 400 MHz – 4 800 MHz, 4 990 MHz – 5 000 MHz	4 400 MHz – 4 800 MHz, 4 990 MHz – 5 000 MHz	TDD	Not Identified for IMT in RR
n96 <sup>(4)</sup>	5 925 MHz – 6 425 MHz	5 925 MHz – 6 425 MHz	TDD <sup>(3)</sup>	Not Identified for IMT in RR
n99 <sup>(6)</sup>	1 626.5 MHz – 1 660.5 MHz	N/A	SUL	Not Identified for IMT in RR
n102 <sup>(4)</sup>	5 925 MHz – 6 425 MHz	5925 MHz – 6 425 MHz	TDD <sup>(3)</sup>	Not Identified for IMT in RR

- (1) This band is applicable in China only.
- (2) Variable duplex operation does not enable dynamic variable duplex configuration by the network and is used such that DL and UL frequency ranges are supported independently in any valid frequency range for the band.
- (3) This band is restricted to operation with shared spectrum channel access as defined in TS 37.213 [4].
- (4) This band is applicable only in countries/regions designating this band for shared-spectrum access use subject to country-specific conditions.
- (5) The requirements for this band are applicable only where no other NR or E-UTRA TDD operating band(s) are used within the frequency range of this band in the same geographical area. For scenarios where other NR or E-UTRA TDD operating band(s) are used within the frequency range of this band in the same geographical area, special co-existence requirements may apply that are not covered by the 3GPP specifications.
- (6) UL operation is restricted to 1 627.5-1 637.5 MHz and 1 646.5-1 656.5 MHz per FCC Order DA 20-48.
- (7) DL operation is restricted to 1 526-1536 MHz frequency range. UL operation is restricted to 1 627.5-1 637.5 MHz and 1 646.5-1 656.5 MHz per FCC Order DA 20-48.
- (8) This band is applicable only in countries/regions designating this band for IMT licensed operation in accordance with RCC Recommendation 1/21.

TABLE 1-3A

**NR operating bands in FR2**

**Frequency bands utilized in E-UTRA and identified for IMT in the RR**

NR operating band number	Uplink (UL) and Downlink (DL) operating band BS transmit/receive UE transmit/receive $F_{UL,low} - F_{UL,high}$ $F_{DL,low} - F_{DL,high}$	Duplex mode	Footnote(s) Identifying the band, or part thereof, for IMT in various countries/Regions
n257	26 500 MHz – 27 500 MHz	TDD	5.532AB
n258	24 250 MHz – 27 500 MHz	TDD	5.532AB
n259	39 500 MHz – 43 500 MHz	TDD	5.550B
n260	37 000 MHz – 40 000 MHz	TDD	5.550B
n262	47 200 MHz – 48 200 MHz	TDD	5.553B
n263	66 000 MHz – 71 000 MHz	TDD	5.559AA

*Editor's Note: Additional Column is under consideration and is not yet agreed.*

TABLE 1-3B  
NR operating bands in FR2  
Frequency bands utilized in E-UTRA and NOT identified for IMT in the RR

NR operating band number	Uplink (UL) and Downlink (DL) operating band BS transmit/receive UE transmit/receive $F_{UL,low} - F_{UL,high}$ $F_{DL,low} - F_{DL,high}$	Duplex mode	Footnote(s) Identifying the band, or part thereof, for IMT in various countries/Regions
n257	27 500 MHz – 29 000 MHz	TDD	Not Identified for IMT in RR
n261	27 500 MHz – 28 350 MHz	TDD	Not Identified for IMT in RR
n263	57 000 MHz – 66 000 MHz	TDD	Not Identified for IMT in RR

*Editor's Note: Additional Column is under consideration and is not yet agreed.*

## 2 Definitions, symbols and abbreviations

### 2.1 Definitions

**basic limit:** emissions limit relating to the power supplied by a single transmitter to a single antenna transmission line in Recommendation ITU-R SM.329 [3] used for the formulation of unwanted emission requirements for FR1.

**antenna connector:** connector at the conducted interface of the BS type 1-C.

**BS type 1-C:** NR base station operating at FR1 with requirements set consisting only of conducted requirements defined at individual antenna connectors.

**BS type 1-H:** NR base station operating at FR1 with a requirement set consisting of conducted requirements defined at individual TAB connectors and OTA requirements defined at RIB.

**BS type 1-O:** NR base station operating at FR1 with a requirement set consisting only of OTA requirements defined at the RIB.

**BS type 2-O:** NR base station operating at FR2 with a requirement set consisting only of OTA requirements defined at the RIB.

**Inter RF Bandwidth gap:** frequency gap between two consecutive Base Station RF Bandwidths that are placed within two supported operating bands.

**NB-IoT operation in NR in-band:** NB-IoT is operating in-band when it is located within a NR transmission bandwidth configuration plus 15 kHz at each edge but not within the NR minimum guard band  $GB_{Channel}$ .

**Operating band:** frequency range in which NR operates (paired or unpaired), that is defined with a specific set of technical requirements.

NOTE: The operating band(s) for a BS is declared by the manufacturer according to the designations in Tables 1-2 and 1-3.

**radiated interface boundary:** operating band specific radiated requirements reference where the radiated requirements apply.

NOTE: For requirements based on EIRP, the radiated interface boundary is associated to the far-field region.



**TAB connector:** transceiver array boundary connector.

**TAB connector RX min cell group:** operating band specific declared group of TAB connectors to which BS type 1-H conducted RX requirements are applied.

NOTE: Within this definition, the group corresponds to the group of TAB connectors which are responsible for receiving a cell when the BS type 1-H setting corresponding to the declared minimum number of cells with reception on all TAB connectors supporting an operating band, but its existence is not limited to that condition.

**TAB connector TX min cell group:** operating band specific declared group of TAB connectors to which BS type 1-H conducted TX requirements are applied.

NOTE: Within this definition, the group corresponds to the group of TAB connectors which are responsible for transmitting a cell when the BS type 1-H setting corresponding to the declared minimum number of cells with transmission on all TAB connectors supporting an operating band, but its existence is not limited to that condition.

**transceiver array boundary:** conducted interface between the transceiver unit array and the composite antenna.

## 2.2 Symbols

$BW_{\text{Config}}$	Transmission bandwidth configuration, expressed in MHz, where $BW_{\text{Config}} = N_{\text{RB}} \times \text{SCS} \times 12 \text{ kHz}$
$F_{\text{DL\_low}}$	Lowest frequency of the downlink operating band
$F_{\text{DL\_high}}$	Highest frequency of the downlink operating band
$F_{\text{UL\_low}}$	Lowest frequency of the uplink operating band
$F_{\text{UL\_high}}$	Highest frequency of the uplink operating band
$\Delta f_{\text{OBUe}}$	Maximum offset of the operating band unwanted emissions mask from the downlink operating band edge
$N_{\text{RB}}$	Transmission bandwidth configuration, expressed in resource blocks
$N_{\text{TXU, counted}}$	The number of active transmitter units as calculated in clause 3.1, that are taken into account for conducted TX output power limit in clause 3.1.2, and for unwanted TX emissions scaling
$N_{\text{TXU, counted per cell}}$	The number of active transmitter units that are taken into account for conducted TX emissions scaling per cell, as calculated in clause 3.1

## 2.3 Abbreviations

ACLR	Adjacent Channel Leakage Ratio
CA	Carrier Aggregation
CACLR	Cumulative ACLR
CLTA	Co-Location Test Antenna
DTT	Digital terrestrial television
EIRP	Effective Isotropic Radiated Power
FR	Frequency Range
GPS	The Global Positioning System
OTA	Over-The-Air

PHS	Personal Handyphone System
RIB	Radiated Interface Boundary
SCS	Sub-Carrier Spacing
TAB	Transceiver Array Boundary
TRP	Total Radiated Power

## 2.4 Conducted and radiated reference points

The manufacturer can declare the NR BS to be one of the following BS types:

- BS type 1-C: Requirements are applied at the BS antenna connector (port A) for a single transmitter or receiver with a full complement of transceivers for the configuration in normal operating conditions. If any external apparatus such as an amplifier, a filter or the combination of such devices is used, requirements apply at the far end antenna connector (port B).

FIGURE 2-1

### BS type 1-C transmitter interface

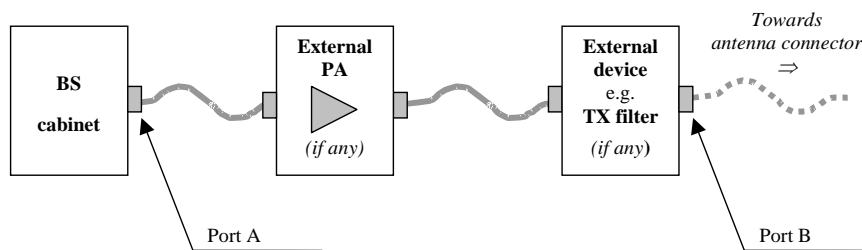
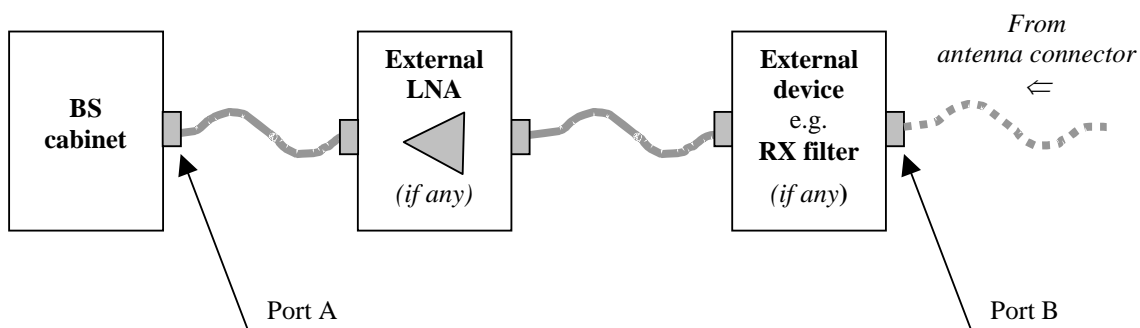

FIGURE 2-2

### BS type 1-C receiver interface



- BS type 1-H: Requirements are defined for two points of reference, signified by radiated requirements and conducted requirements. Radiated characteristics are defined over the air (OTA), where the operating band specific radiated interface is referred to as the Radiated Interface Boundary (RIB). The (spatial) characteristics in which the OTA requirements apply are detailed for each requirement. Conducted characteristics are defined at individual or groups of TAB connectors at the transceiver array boundary,

which is the conducted interface between the transceiver unit array and the composite antenna.

FIGURE 2-3  
**Radiated and conducted reference points for BS type 1-H**

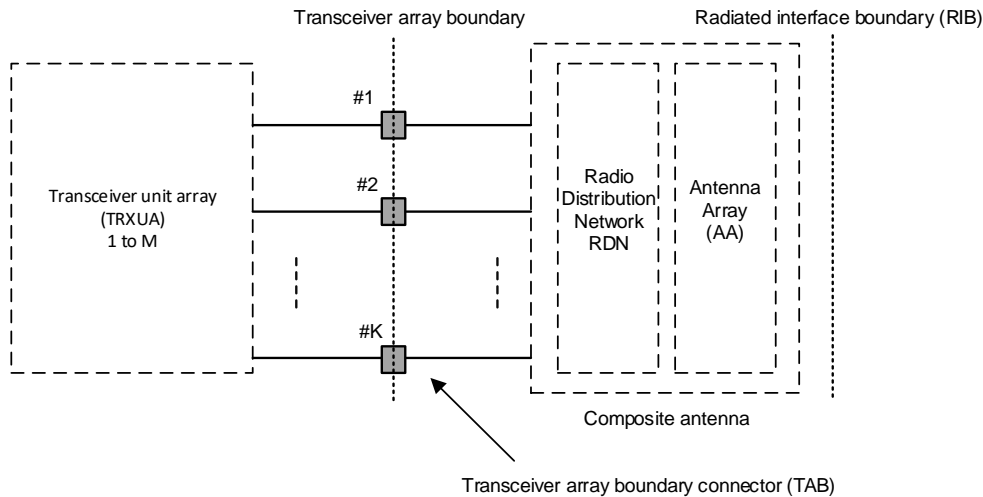

The transceiver unit array is part of the composite transceiver functionality generating modulated transmit signal structures and performing receiver combining and demodulation.

The transceiver unit array contains an implementation specific number of transmitter units and an implementation specific number of receiver units. Transmitter units and receiver units may be combined into transceiver units. The transmitter/receiver units have the ability to transmit/receive parallel independent modulated symbol streams.

The composite antenna contains a radio distribution network (RDN) and an antenna array. The RDN is a linear passive network which distributes the RF power generated by the transceiver unit array to the antenna array, and/or distributes the radio signals collected by the antenna array to the transceiver unit array, in an implementation specific way.

How a conducted requirement is applied to the transceiver array boundary is requirement specific.

- BS type 1-O: Radiated characteristics for BS type 1-O are defined over the air (OTA) where the operating band specific radiated interface is referred to as the Radiated Interface Boundary (RIB). The (spatial) characteristics in which the OTA requirements apply are requirement specific.

FIGURE 2-4

**General architecture of BS type 1-O and BS type 2-O**

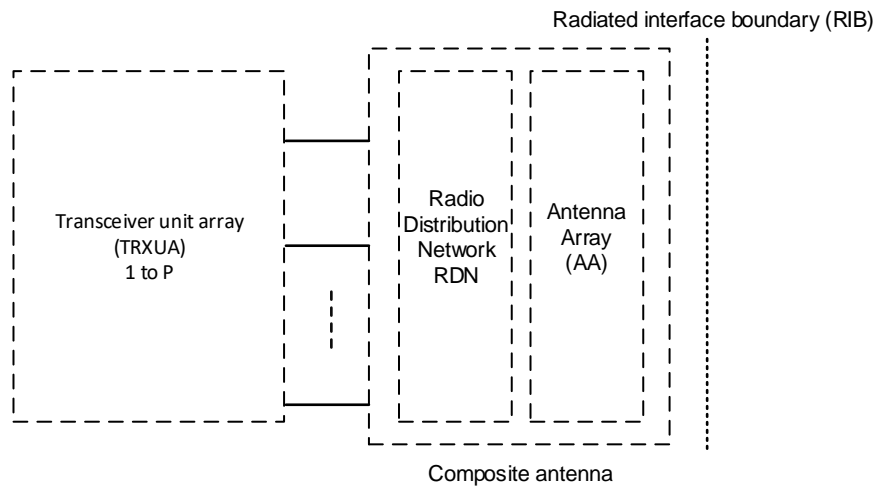

- BS type 2-O: OTA requirements defined at the RIB only, same as for the BS type 1-O.

## 2.5 Base station classes

Some requirements apply specifically to a specific BS class. The BS classes for NR are Wide Area Base Stations, Medium Range Base Stations and Local Area Base Stations.

BS classes for BS type 1-C and BS type 1-H are defined as indicated below:

- Wide Area Base Stations are characterised by requirements derived from Macro Cell scenarios with a BS to UE minimum coupling loss equal to 70 dB.
- Medium Range Base Stations are characterised by requirements derived from Micro Cell scenarios with a BS to UE minimum coupling loss equals to 53 dB.
- Local Area Base Stations are characterised by requirements derived from Pico Cell scenarios with a BS to UE minimum coupling loss equal to 45 dB.

BS classes for BS type 1-O and BS type 2-O are defined as indicated below:

- Wide Area Base Stations are characterised by requirements derived from Macro Cell scenarios with a BS to UE minimum distance along the ground equal to 35 m.
- Medium Range Base Stations are characterised by requirements derived from Micro Cell scenarios with a BS to UE minimum distance along the ground equal to 5 m.
- Local Area Base Stations are characterised by requirements derived from Pico Cell scenarios with a BS to UE minimum distance along the ground equal to 2 m.

## 3 NR generic unwanted emission characteristics for BS type 1-C and BS type 1-H

The maximum offset of the operating band unwanted emissions mask from the operating band edge is  $\Delta f_{OBUE}$ . The operating band unwanted emissions define all unwanted emissions in each supported downlink operating band plus the frequency ranges  $\Delta f_{OBUE}$  above and  $\Delta f_{OBUE}$  below each band. Unwanted emissions outside of this frequency range are limited by a spurious emissions requirement.

The values of  $\Delta f_{OBUE}$  are defined in table 3-1 for the NR operating bands.

TABLE 3-1

**Maximum offset of OBUE outside the downlink operating band**

BS type	Operating band characteristics	$\Delta f_{\text{OBUE}}$ (MHz)
BS type 1-C	$F_{\text{DL\_high}} - F_{\text{DL\_low}} \leq 200$ MHz	10
	$200 \text{ MHz} < F_{\text{DL\_high}} - F_{\text{DL\_low}} \leq 900$ MHz	40
BS type 1-H	$F_{\text{DL\_high}} - F_{\text{DL\_low}} < 100$ MHz	10
	$100 \text{ MHz} \leq F_{\text{DL\_high}} - F_{\text{DL\_low}} \leq 900$ MHz	40

For band n46, n96 and n102, the values of  $\Delta f_{\text{OBUE}}$  are defined in Table 3-2.

TABLE 3-2

**Maximum offset of OBUE outside the downlink operating band**

Operating band	$\Delta f_{\text{OBUE}}$ (MHz)
n46, n102	40
n96	50

For BS type 1-H, the manufacturer shall declare the minimum number of supported geographical cells (i.e., geographical areas). The minimum number of supported geographical cells ( $N_{\text{cells}}$ ) relates to the BS setting with the minimum amount of cell splitting supported with transmission on all TAB connectors supporting the operating band. The manufacturer shall also declare TAB connector TX min cell groups. Every TAB connector supporting transmission in an operating band shall map to one TAB connector TX min cell group supporting the same operating band. The mapping of TAB connectors to cells is implementation dependent.

The number of active transmitter units that are considered when calculating the emissions limit ( $N_{\text{TXU, counted}}$ ) for BS type 1-H is calculated as follows:

$$N_{\text{TXU, counted}} = \min(N_{\text{TXU, active}}, 8 \cdot N_{\text{cells}})$$

Further:

$$N_{\text{TXU, counted per cell}} = N_{\text{TXU, counted}} / N_{\text{cells}}$$

$N_{\text{TXU, counted per cell}}$  is used for scaling the basic limits.

NOTE:  $N_{\text{TXU, active}}$  depends on the actual number of active transmitter units and is independent to the declaration of  $N_{\text{cells}}$ .

### 3.1 Conducted operating band unwanted emissions

#### 3.1.1 Conducted Operating band unwanted emissions for BS type 1-C

The operating band unwanted emissions for BS type 1-C for each antenna connector shall be below the applicable basic limits defined in clauses 3.1.3 – 3.1.8.

For Band n41 and n90 operation in Japan, the operating band unwanted emissions limits shall be applied to the sum of the emission power over all antenna connectors for BS type 1-C.

### 3.1.2 Conducted Operating band unwanted emissions BS type 1-H

The operating band unwanted emissions for BS type 1-H are that for each TAB connector TX min cell group and each applicable basic limit in clauses 3.1.3 – 3.1.8, the power summation emissions at the TAB connectors of the TAB connector TX min cell group shall not exceed a BS limit specified as the basic limit + X, where  $X = 10\log_{10}(N_{TXU, \text{counted per cell}})$ .

NOTE: Conformance to the BS type 1-H emission requirement can be demonstrated by meeting at least one of the following criteria as determined by the manufacturer:

- 1) The sum of the emissions power measured on each TAB connector in the TAB connector TX min cell group shall be less than or equal to the limit as defined in this clause for the respective frequency span.

Or

- 2) The unwanted emissions power at each TAB connector shall be less than or equal to the BS type 1-H limit as defined in this clause for the respective frequency span, scaled by  $-10\log_{10}(n)$ , where n is the number of TAB connectors in the TAB connector TX min cell group.

### 3.1.3 Basic limits for Wide Area BS (Category A)

For BS operating in Bands n5, n8, n12, n13, n14, n18, n26, n28, n29, n71, n85, basic limits are specified in Table 6.6.4.5.2-1 of TS 38.141-1 [1].

For BS operating in Bands n1, n2, n3, n7, n24, n25, n30, n34, n38, n39, n40, n41, n50, n65, n66, n70, n74, n75, n92, n94, basic limits are specified in Table 6.6.4.5.2-2 of TS 38.141-1 [1]:

For BS operating in Bands n48, n77, n78, n79, basic limits are specified in Table 6.6.4.5.2-3 of TS 38.141-1 [1].

### 3.1.4 Basic limits for Wide Area BS (Category B)

For Category B Operating band unwanted emissions, there are two options for the basic limits that may be applied regionally. Either the basic limits in clause 6.6.4.2.2.1 or clause 6.6.4.2.2.2 shall be applied.

#### 3.1.4.1 Category B requirements (Option 1)

For BS operating in Bands n5, n8, n12, n20, n26, n28, n29, n67, n71, n85, basic limits are specified in Table 6.6.4.5.3.1-1 of TS 38.141-1 [1].

For BS operating in Bands n1, n2, n3, n7, n25, n34, n38, n39, n40, n41, n50, n65, n66, n70, n75, n92, n94, basic limits are specified in Tables 6.6.4.5.3.1-2 of TS 38.141-1 [1].

For BS operating in Bands n48, n77, n78, n79, basic limits are specified in Table 6.6.4.5.3.1-3 of TS 38.141-1 [1].

#### 3.1.4.2 Category B requirements (Option 2)

The limits in this clause are intended for Europe and may be applied regionally for BS operating in Bands n1, n3, n7, n8, n38, n65 or n101.

For a BS operating in Bands n1, n3, n8, n65 or BS type 1-C operating in bands n7, n38 or n101 basic limits are specified in Table 6.6.4.5.3.2-1 of TS 38.141-1 [1].

### 3.1.5 Basic limits for Medium Range BS (Category A and B)

For Medium Range BS in NR bands  $\leq 3$  GHz, basic limits are specified in Table 6.6.4.5.4-1 and table 6.6.4.5.4-2 of TS 38.141-1 [1].

For Medium Range BS in NR bands > 3 GHz, basic limits are specified in Table 6.6.4.5.4-3 and table 6.6.4.5.4-4 of TS 38.141-1 [1].

### **3.1.6 Basic limits for Local Area BS (Category A and B)**

For Local Area BS in NR bands  $\leq$  3 GHz, basic limits are specified in Table 6.6.4.5.5-1 of TS 38.141-1 [1].

For Local Area BS in NR bands > 3 GHz, basic limits are specified in Table 6.6.4.5.5-2 of TS 38.141-1 [1].

### **3.1.7 Basic limits for Local Area and Medium Range BS for band n46, n96 and n102 (Category A and B)**

For Local Area and Medium Range BS operating in Band n46, basic limits for 10 MHz channel bandwidth are specified in Table 6.6.4.5.5A-1 of TS 38.141-1 [1]. For Local Area and Medium Range BS operating in Band n46, n96 and Band n102, basic limits for 20 MHz, 40 MHz, 60 MHz and 80 MHz channel bandwidth are specified in Table 6.6.4.5.5A-2 of TS 38.141-1 [1]. For one non-transmitted channel basic limits are specified in Table 6.6.4.5.5A-3 of TS 38.141-1 [1], and for two non-transmitted channels basic limits are specified in Table 6.6.4.5.5A-4 of TS 38.141-1 [1].

In the case of one or two non-transmitted 20 MHz channels between transmitted channels, when a NR-U channel bandwidth of 60 MHz or 80 MHz have been assigned, the spectrum emission mask for non-transmitted channels specified in Tables 6.6.4.5.5A-3 and 6.6.4.5.5A-4 of TS 38.141-1 [1] applies for one and two non-transmitted channels respectively. The relative power of any BS emission shall not exceed the most stringent levels given by Tables 6.6.4.5.5A-2 and 6.6.4.5.5A-3 of TS 38.141-1 [1] in the case of non-transmitted channels between transmitted channels.

### **3.1.8 Basic limits for additional requirements**

In certain regions the following additional requirements may apply:

- For protection of DTT, the requirement in clause 6.6.4.5.6.2 of TS 38.141-1 [1].
- For operation in Band n48, the requirement in clause 6.6.4.5.6.3 of TS 38.141-1 [1].
- For operation in Band n53, the requirement in clause 6.6.4.5.6.4 of TS 38.141-1 [1].
- For protection of GPS, the requirement in clause 6.6.4.5.6.5 of TS 38.141-1 [1].
- For operation with shared spectrum channel access, the requirement in clause 6.6.4.5.6.6 of TS 38.141-1 [1].

## **3.2 Conducted Adjacent channel leakage ratio (ACLR)**

### **3.2.1 General requirements**

Adjacent Channel Leakage power Ratio (ACLR) is the ratio of the filtered mean power centred on the assigned channel frequency to the filtered mean power centred on an adjacent channel frequency.

The assumed filter for the adjacent channel frequency is defined in Tables 6.6.3.5.2-1, 6.6.3.5.2-1a, 6.6.3.5.2-3 and 6.6.3.5.2-3a of TS 38.141-1 [1] and a square filter of bandwidth equal to the transmission bandwidth configuration of the transmitted signal ( $BW_{\text{Config}}$ ) centred on the assigned channel frequency.

### **3.2.2 Limits and basic limits**

For operation in paired and unpaired spectrum except for band n46, n96 and n102, the ACLR shall be higher than the value specified in Table 6.6.3.5.2-1 of TS 38.141-1 [1].

For operation in non-contiguous spectrum or multiple bands except for band n46, n96 and n102, the ACLR shall be higher than the value specified in Table 6.6.3.5.2-3 of TS 38.141-1 [1].

For band n46, n96 and n102, the ACLR shall be higher than the value specified in Table 6.6.3.5.2-1a of TS 38.141-1 [1].

For operation in non-contiguous spectrum for band n46, n96 and n102, the ACLR shall be higher than the value specified in Table 6.6.3.2-3a of TS 38.141-1 [1].

The ACLR absolute basic limit is specified in Table 6.6.3.5.2-2 of TS 38.141-1 [1].

### 3.2.3 BS type 1-C

For operation in paired and unpaired spectrum except for band n46, n96 and n102, the ACLR test requirements for BS type 1-C are given in Tables 6.6.3.5.2-1 or 6.6.3.5.2-3 of TS 38.141-1 [1] applies per antenna connector. Conformance can be shown by meeting the ACLR limit in Tables 6.6.3.5.2-1 or 6.6.3.5.2-3 of TS 38.141-1 [1], or the absolute basic limits in Table 6.6.3.5.2-2 of TS 38.141-1 [1], whichever is less stringent.

For operation in band n46, n96 and n102, the ACLR test requirements for BS type 1-C are given in table 6.6.3.5.2-1a or 6.6.3.5.2-3a of TS 38.141-1 [1] applies per antenna connector. Conformance can be shown by meeting the ACLR limit in Tables 6.6.3.5.2-1a or 6.6.3.5.2-3a of TS 38.141-1 [1], or the absolute basic limits in Table 6.6.3.5.2-2 of TS 38.141-1 [1], whichever is less stringent.

For Band n41 and n90 operation in Japan, absolute ACLR limits shall be applied to the sum of the absolute ACLR power over all antenna connectors for BS type 1-C.

### 3.2.4 BS type 1-H

The ACLR absolute basic limits in Table 6.6.3.5.2-2 of TS 38.141-1 [1] + X (where  $X = 10\log_{10}(N_{TXU, \text{counted per cell}})$ ) or the ACLR limits in Tables 6.6.3.5.2-1 or 6.6.3.5.2-3 of TS 38.141-1 [1], whichever is less stringent, shall apply for each TAB connector TX min cell group.

Conformance to the BS type 1-H ACLR limit can be demonstrated by meeting at least one of the following criteria as determined by the manufacturer:

- 1) The ratio of the sum of the filtered mean power measured on each TAB connector in the TAB connector TX min cell group at the assigned channel frequency to the sum of the filtered mean power measured on each TAB connector in the TAB connector TX min cell group at the adjacent channel frequency shall be greater than or equal to the ACLR limit of the BS. This shall apply for each TAB connector TX min cell group.

Or

- 2) The ratio of the filtered mean power at the TAB connector centred on the assigned channel frequency to the filtered mean power at this TAB connector centred on the adjacent channel frequency shall be greater than or equal to the ACLR limit of the BS for every TAB connector in the TAB connector TX min cell group, for each TAB connector TX min cell group.

In case the ACLR absolute basic limit of BS type 1-H are applied, the conformance can be demonstrated by meeting at least one of the following criteria as determined by the manufacturer:

- 1) The sum of the filtered mean power measured on each TAB connector in the TAB connector TX min cell group at the adjacent channel frequency shall be less than or equal to the ACLR absolute basic limit + X (where  $X =$



$10\log_{10}(N_{\text{TXU,countedpercell}})$  of the BS. This shall apply to each TAB connector TX min cell group.

Or

- 2) The filtered mean power at each TAB connector centred on the adjacent channel frequency shall be less than or equal to the ACLR absolute basic limit of the BS scaled by  $X - 10\log_{10}(n)$  for every TAB connector in the TAB connector TX min cell group, for each TAB connector TX min cell group, where  $n$  is the number of TAB connectors in the TAB connector TX min cell group.

### **3.3 Conducted Cumulative adjacent channel leakage ratio (CACLR)**

#### **3.3.1 General requirements**

The Cumulative Adjacent Channel Leakage power Ratio (CACLR) in a sub-block gap or the Inter RF Bandwidth gap is the ratio of:

- a) the sum of the filtered mean power centred on the assigned channel frequencies for the two carriers adjacent to each side of the sub-block gap or the Inter RF Bandwidth gap, and
- b) the filtered mean power centred on a frequency channel adjacent to one of the respective sub-block edges or Base Station RF Bandwidth edges.

The assumed filter for the adjacent channel frequency is defined in Table 6.6.3.5.2-4 of TS 38.141-1 [1] and the filters on the assigned channels are defined in Table 6.6.3.5.2-6 of TS 38.141-1 [1].

#### **3.3.2 Limits and basic limits**

For operation in non-contiguous spectrum or multiple bands except for band n46, n96 and n102, the CACLR for NR carriers located on either side of the sub-block gap or the Inter RF Bandwidth gap shall be higher than the value specified in Table 6.6.3.5.2-4 of TS 38.141-1 [1].

For operation in non-contiguous spectrum for band n46, n96 and n102, the CACLR for NR carriers located on either side of the sub-block gap shall be higher than the value specified in Table 6.6.3.5.2-4a of TS 38.141-1 [1].

The CACLR absolute basic limit is specified in Table 6.6.3.5.2-5 of TS 38.141-1 [1].

#### **3.3.3 BS type 1-C**

The CACLR test requirements for BS type 1-C are given in Table 6.6.3.5.2-4 of TS 38.141-1 [1] applies per antenna connector. Conformance can be shown by meeting the CACLR limit in Table 6.6.3.5.2-4 of TS 38.141-1 [1] or the absolute basic limits in Table 6.6.3.5.2-5 of TS 38.141-1 [1], whichever is less stringent.

#### **3.3.4 BS type 1-H**

The CACLR absolute basic limits in Table 6.6.3.5.2-5 of TS 38.141-1 [1] +  $X$ , (where  $X = 10\log_{10}(N_{\text{TXU,countedpercell}})$ ) or the CACLR limits in Table 6.6.3.5.2-4 of TS 38.141-1 [1], whichever is less stringent, shall apply for each TAB connector TX min cell group.

Conformance to the BS type 1-H CACLR limit can be demonstrated by meeting at least one of the following criteria as determined by the manufacturer:

- 1) The ratio of the sum of the filtered mean power measured on each TAB connector in the TAB connector TX min cell group at the assigned channel frequency to the sum of the filtered mean power measured on each TAB connector in the TAB connector TX min cell group at the adjacent channel

frequency shall be greater than or equal to the CA CLR limit of the BS. This shall apply for each TAB connector TX min cell group.

Or

- 2) The ratio of the filtered mean power at the TAB connector centred on the assigned channel frequency to the filtered mean power at this TAB connector centred on the adjacent channel frequency shall be greater than or equal to the CA CLR limit of the BS for every TAB connector in the TAB connector TX min cell group, for each TAB connector TX min cell group.

In case the CA CLR absolute basic limit of BS type 1-H are applied, the conformance can be demonstrated by meeting at least one of the following criteria as determined by the manufacturer:

- 1) The sum of the filtered mean power measured on each TAB connector in the TAB connector TX min cell group at the adjacent channel frequency shall be less than or equal to the CA CLR absolute basic limit + X (where  $X = 10\log_{10}(N_{\text{TXU, counted per cell}})$ ) of the BS. This shall apply to each TAB connector TX min cell group.

Or

- 2) The filtered mean power at each TAB connector centred on the adjacent channel frequency shall be less than or equal to the CA CLR absolute basic limit of the BS scaled by  $X - 10\log_{10}(n)$  for every TAB connector in the TAB connector TX min cell group, for each TAB connector TX min cell group, where n is the number of TAB connectors in the TAB connector TX min cell group.

### **3.4 Conducted Transmitter spurious emissions**

#### **3.4.1 Conducted transmitter spurious emissions for BS type 1-C**

The Tx spurious emissions for BS type 1-C for each antenna connector shall not exceed the applicable basic limits defined in clauses 3.4.3 – 3.4.6.

For Band n41 and n90 operation in Japan, the sum of the spurious emissions over all antenna connectors for BS type 1-C shall not exceed the basic limits defined in clauses 3.4.3 – 3.4.6.

#### **3.4.2 Conducted transmitter spurious emissions for BS type 1-H**

The Tx spurious emissions requirements for BS type 1-H are that for each TAB connector TX min cell group and each applicable basic limit in clauses 3.4.3 – 3.4.6, the power summation emissions at the TAB connectors of the TAB connector TX min cell group shall not exceed a limit specified as the basic limit + X, where  $X = 10\log_{10}(N_{\text{TXU, counted per cell}})$ , unless stated differently in regional regulation.

NOTE: Conformance to the BS type 1-H spurious emission requirement can be demonstrated by meeting at least one of the following criteria as determined by the manufacturer:

- 1) The sum of the emissions power measured on each TAB connector in the TAB connector TX min cell group shall be less than or equal to the limit as defined in this clause for the respective frequency span.

Or

- 2) The unwanted emissions power at each TAB connector shall be less than or equal to the BS type 1-H limit as defined in this clause for the respective frequency span, scaled by  $-10\log_{10}(n)$ , where n is the number of TAB connectors in the TAB connector TX min cell group.

### 3.4.3 Basic limits for transmitter spurious emissions

The limits of either Table 6.6.5.5.1.1-1 in TS 38.141-1 [1] for Category A or Table 6.6.5.5.1.1-2 in TS 38.141-1 [1] for Category B shall apply. The application of either Category A or Category B limits shall be the same as for operating band unwanted emissions in clause 3.1, and as declared by the manufacturer.

### 3.4.4 Protection of the BS receiver of own or different BS

This requirement shall be applied for NR FDD operation in order to prevent the receivers of the BSs being desensitised by emissions from a BS transmitter. It is measured at the transmit antenna connector for BS type 1-C or at the TAB connector for BS type 1-H for any type of BS which has common or separate Tx/Rx antenna connectors / TAB connectors.

The basic limits are provided in Table 6.6.5.5.1.2-1 in TS 38.141-1 [1].

### 3.4.5 Additional spurious emission requirements

In certain regions the following additional requirements in TS 38.141-1 [1] may apply:

- For BS co-existence with systems operating in other frequency bands, the requirement in Table 6.6.5.5.1.3-1.
- For protection of PHS, the requirement in Table 6.6.5.5.1.3-2.
- For BS operating in Band n50 and n75 within 1 432-1 452 MHz, and in Band n51 and Band n76, the requirement in Table 6.6.5.5.1.3-4.
- For BS operating in NR Band n50 and n75 within 1 492-1 517 MHz, and in Band n74 within 14 92-1 518 MHz, the requirements in Table 6.6.5.5.1.3-5.
- For BS operating in Band n13 and n14, the requirements in Table 6.6.5.5.1.3-6.
- For BS operating in Band n30, the requirements in Table 6.6.5.5.1.3-7.
- For BS operating in Band n48, the requirements in Table 6.6.5.5.1.3-8.
- For BS operating in Band n26 for protection of 800 MHz public safety operations, the requirements in Table 6.6.5.5.1.3-9.
- For BS operating in Band n41 and n90 in Japan, the requirements in Table 6.6.5.5.1.3-10.
- For BS operating in 3.45-3.55 GHz in Band n77 in certain regions, the requirements in Table 6.6.5.5.1.3-11.
- For BS operating in Band n101 in CEPT countries, the requirements in Table 6.6.5.5.1.3-12.

For BS operating in Band n100 in CEPT countries, the requirements in Table 6.6.5.5.1.3-13.

### 3.4.6 Co-location with other base stations

These requirements may be applied for the protection of other BS receivers when GSM900, DCS1800, PCS1900, GSM850, CDMA850, UTRA FDD, UTRA TDD, E-UTRA and/or NR BS are co-located with a BS.

The requirements assume a 30 dB coupling loss between transmitter and receiver and are based on co-location with base stations of the same class.

The basic limits are in Table 6.6.5.5.1.4-1 in TS 38-141-1 [1] for a BS where requirements for co-location with a BS type listed in the first column apply, depending on the declared BS class. For a multi-band connector, the exclusions and conditions in the Note column of Table 6.6.5.5.1.4-1 shall apply for each supported operating band.

### 3.5 Conducted receiver spurious emissions

#### 3.5.1 Conducted receiver spurious emissions BS type 1-C

The receiver spurious emissions for BS type 1-C for each antenna connector shall be below the applicable basic limits defined in clause 3.5.3.

For Band n41 and n90 operation in Japan, the sum of RX spurious emissions over all antenna connectors for BS type 1-C shall not exceed basic limits defined in clause 3.5.3.

#### 3.5.2 Conducted receiver spurious emissions BS type 1-H

The receiver spurious emissions for BS type 1-H are that for each TAB connector TX min cell group and each applicable basic limit in clause 3.5.3, the power summation emissions at the TAB connectors of the TAB connector TX min cell group shall not exceed a BS limit specified as the basic limit + X, where  $X = 10\log_{10}(N_{\text{TXU, counted per cell}})$ , unless stated differently in regional regulation.

NOTE: Conformance to the BS type 1-H emission requirement can be demonstrated by meeting at least one of the following criteria as determined by the manufacturer:

- 1) The sum of the emissions power measured on each TAB connector in the TAB connector TX min cell group shall be less than or equal to the limit as defined in this clause for the respective frequency span.
- Or
- 2) The unwanted emissions power at each TAB connector shall be less than or equal to the BS type 1-H limit as defined in this clause for the respective frequency span, scaled by  $-10\log_{10}(n)$ , where n is the number of TAB connectors in the TAB connector TX min cell group.

#### 3.5.3 Basic limits for receiver spurious emissions

Basic limits for receiver spurious emissions are specified in Table 7.6.5.1-1 of TS 38.141-1 [1].

## 4 NR generic unwanted emission characteristics for BS type 1-O and BS type 2-O

The maximum offset of the operating band unwanted emissions mask from the operating band edge is  $\Delta f_{\text{OBUE}}$ . The value of  $\Delta f_{\text{OBUE}}$  is defined in table 4-1 for BS type 1-O and BS type 2-O for the NR operating bands.

TABLE 4-1

Maximum offset  $\Delta f_{\text{OBUE}}$  outside the downlink operating band

BS type	Operating band characteristics	$\Delta f_{\text{OBUE}}$ (MHz)
BS type 1-O	$F_{\text{DL\_high}} - F_{\text{DL\_low}} < 100$ MHz	10
	$100 \text{ MHz} \leq F_{\text{DL\_high}} - F_{\text{DL\_low}} \leq 900$ MHz	40
BS type 2-O	$F_{\text{DL\_high}} - F_{\text{DL\_low}} \leq 4\,000$ MHz	1 500

## **4.1 OTA Operating band unwanted emissions**

### **4.1.1 OTA Operating band unwanted emissions BS type 1-O**

For BS type 1-O, for a RIB operating in multi-carrier or contiguous CA, the requirements apply to BS channel bandwidths of the outermost carrier. In addition, for a RIB operating in non-contiguous spectrum, the requirements shall apply inside any sub-block gap. In addition, for a multi-band RIB, the requirements shall apply inside any Inter RF Bandwidth gap.

#### **4.1.1.1 Wide Area BS (Category A)**

For a RIB operating in Bands n5, n8, n12, n13, n14, n26, n28, n29, n71, n85, emissions shall not exceed the maximum levels specified in Table 6.7.4.5.1.1-1 of TS 38.141-2 [2].

For a RIB operating in Bands n1, n2, n3, n7, n25, n30, n34, n38, n39, n40, n41, n50, n65, n66, n70, n74, n75, n77, n78, n79, emissions shall not exceed the maximum levels specified in Tables 6.7.4.5.1.1-2 to 6.7.4.5.1.1-4 of TS 38.141-2 [2].

#### **4.1.1.2 Wide Area BS Category B (Option 1)**

For a RIB operating in Bands n5, n8, n12, n20, n26, n28, n29, n67, n71, n85, emissions shall not exceed the maximum levels specified in Table 6.7.4.5.1.2-1 of TS 38.141-2 [2].

For a RIB operating in Bands n1, n2, n3, n7, n25, n34, n38, n39, n40, n41, n50, n65, n66, n70, n75, n77, n78, n79, emissions shall not exceed the maximum levels specified in Tables 6.7.4.5.1.2-2 to 6.7.4.5.1.2-4 of TS 38.141-2 [2].

#### **4.1.1.3 Wide Area BS Category B (Option 2)**

The limits in this clause are intended for Europe and may be applied regionally for a RIB operating in bands n1, n3, n8 and n65.

For a RIB operating in bands n1, n3, n8, n65 emissions shall not exceed the maximum levels specified in Table 6.7.4.5.1.3-1 of TS 38.141-2 [2].

#### **4.1.1.4 Medium Range BS (Category A and Category B)**

For Medium Range BS class in NR bands  $\leq 3$  GHz, emissions shall not exceed the maximum levels specified in Tables 6.7.4.5.1.4-1 and 6.7.4.5.1.4-4 of TS 38.141-2 [2].

For Medium Range BS class in  $3 \text{ GHz} < \text{NR bands} \leq 4.2 \text{ GHz}$ , emissions shall not exceed the maximum levels specified in Tables 6.7.4.5.1.4-2 and 6.7.4.5.1.4-5 of TS 38.141-2 [2].

For Medium Range BS class in  $4.2 \text{ GHz} < \text{NR bands} \leq 6 \text{ GHz}$ , emissions shall not exceed the maximum levels specified in Tables 6.7.4.5.1.4-3 and 6.7.4.5.1.4-6 of TS 38.141-2 [2].

#### **4.1.1.5 Local Area BS (Category A and Category B)**

For Local Area BS class in NR bands  $\leq 3$  GHz, emissions shall not exceed the maximum levels specified in Table 6.7.4.5.1.5-1 of TS 38.141-2 [2].

For Local Area BS class in  $3 \text{ GHz} < \text{NR bands} \leq 4.2 \text{ GHz}$ , emissions shall not exceed the maximum levels specified in Table 6.7.4.5.1.5-2 of TS 38.141-2 [2].

For Local Area BS class in  $4.2 \text{ GHz} < \text{NR bands} \leq 6 \text{ GHz}$ , emissions shall not exceed the maximum levels specified in Table 6.7.4.5.1.5-3 of TS 38.141-2 [2].

#### **4.1.1.6 Additional requirements**

In certain regions the following additional requirements may apply:

- For protection of DTT, the requirement in clause 6.7.4.5.1.6.2 of TS 38.141-1 [1].
- For Protection of GPS, the requirement in clause 6.7.4.5.1.6.3 of TS 38.141-1 [1].
- For operation in Bands n50, n51, n74, n75, n76, the requirement in clause 6.7.4.5.1.6.4 of TS 38.141-1 [1].

#### **4.1.2 OTA Operating band unwanted emissions BS type 2-O**

For BS type 2-O, for a RIB operating in multi-carrier or contiguous CA, the requirements apply to the frequencies starting from the edge of the contiguous transmission bandwidth. In addition, for a RIB operating in non-contiguous spectrum, the requirements apply inside any sub-block gap.

##### **4.1.2.1 OTA operating band unwanted emission limits (Category A)**

The power of unwanted emission shall not exceed the limits in Tables 6.7.4.5.2.2-1, 6.7.4.5.2.2-2 or 6.7.4.5.2.2-3 of TS 38.141-2 [2].

##### **4.1.2.2 OTA operating band unwanted emission limits (Category B)**

The power of unwanted emission shall not exceed the limits in Tables 6.7.4.5.2.3-1, 6.7.4.5.2.3-2 or 6.7.4.5.2.3-3 of TS 38.141-2 [2].

##### **4.1.2.3 Additional OTA operating band unwanted emission limits**

The following additional requirement shall apply:

- For BS operating in the frequency range 24.25 – 27.5 GHz, for protection of Earth Exploration Satellite Service, the requirement in Table 6.7.4.5.2.4.1-1 of TS 38.141-2 [2].

#### **4.2 OTA Adjacent channel leakage ratio (ACLR)**

##### **4.2.1 BS type 1-O**

For the OTA ACLR requirement either the OTA ACLR limits in tables 6.7.3.5.1-1/2a of TS 38.141-2 [2] or the OTA ACLR absolute limits in Table 6.7.3.5.1-2 of TS 38.141-2 [2] shall apply, whichever is less stringent.

The assumed filter for the adjacent channel frequency is defined in table 6.7.3.5.1-3 of TS 38.141-2 [2] and the filters on the assigned channels are defined in Table 6.7.3.5.1-4 of TS 38.141-2 [2].

For operation in paired and unpaired spectrum, the OTA ACLR measurement result shall not be less than the OTA ACLR limit specified in Table 6.7.3.5.1-1 of TS 38.141-2 [2].

The absolute total power measurement shall not exceed the OTA ACLR absolute limit specified in Table 6.7.3.5.1-2 of TS 38.141-2 [2].

For operation in non-contiguous spectrum or multiple bands, the OTA ACLR measurement result shall not be less than the OTA ACLR limit specified in Table 6.7.3.5.1-2a of TS 38.141-2 [2].

##### **4.2.2 BS type 2-O**

For the OTA ACLR requirement either the OTA ACLR limits in tables 6.7.3.5.2-1/3 of TS 38.141-2 [2] or the OTA ACLR absolute limits in Table 6.7.3.5.2-2 of TS 38.141-2 [2] shall apply, whichever is less stringent.

The assumed filter for the adjacent channel frequency is defined in table 6.7.3.5.2-4 of TS 38.141-2 [2] and the filters on the assigned channels are defined in Table 6.7.3.5.2-5 of TS 38.141-2 [2].

The OTA ACLR measurement result shall not be less than the OTA ACLR limit specified in Table 6.7.3.5.2-1 of TS 38.141-2 [2].

The absolute total power measurement shall not exceed the OTA ACLR absolute limit specified in Table 6.7.3.5.2-2 of TS 38.141-2 [2].

For operation in non-contiguous spectrum, the OTA ACLR measurement result shall not be less than the OTA ACLR limit specified in Table 6.7.3.5.2-3 of TS 38.141-2 [2].

### **4.3 OTA Cumulative adjacent channel leakage ratio (CACLR)**

#### **4.3.1 BS type 1-O**

The OTA CACLR limits in table 6.7.3.5.1-3 of TS 38.141-2 [2] or the OTA CACLR absolute limits in Table 6.7.3.5.1-3a of TS 38.141-2 [2] shall apply, whichever is less stringent.

The CACLR in a sub-block gap and Inter RF Bandwidth gap is the ratio of:

- a) the sum of the filtered mean power centred on the assigned channel frequencies for the two carriers adjacent to each side of the sub-block gap or the Inter RF Bandwidth gap, and
- b) the filtered mean power centred on a frequency channel adjacent to one of the respective sub-block edges or Base Station RF Bandwidth edges.

The assumed filter for the adjacent channel frequency is defined in Table 6.7.3.5.1-3 of TS 38.141-2 [2] and the filters on the assigned channels are defined in table 6.7.3.5.1-4 of TS 38.141-2 [2].

The OTA CACLR measurement result shall not less than the OTA CACLR limit specified in Table 6.7.3.5.1-3 of TS 38.141-2 [2].

The absolute total power measurement shall not exceed the OTA CACLR absolute limit specified in Table 6.7.3.5.1-3a of TS 38.141-2 [2].

#### **4.3.2 BS type 2-O**

The OTA CACLR limits in table 6.7.3.5.2-4 of TS 38.141-2 [2] or the OTA CACLR absolute limits in Table 6.7.3.5.2-4a of TS 38.141-2 [2] shall apply, whichever is less stringent.

The CACLR in a sub-block gap is the ratio of:

- a) the sum of the filtered mean power centred on the assigned channel frequencies for the two carriers adjacent to each side of the sub-block gap, and
- b) the filtered mean power centred on a frequency channel adjacent to one of the respective sub-block edges.

The assumed filter for the adjacent channel frequency is defined in Table 6.7.3.5.2-4 of TS 38.141-2 [2] and the filters on the assigned channels are defined in Table 6.7.3.5.2-5 of TS 38.141-2 [2].

For operation in non-contiguous spectrum, the CACLR for carriers located on either side of the sub-block gap shall be less than the value specified in Table 6.7.3.5.2-4 of TS 38.141-2 [2].

The absolute total power measurement shall not exceed the OTA CACLR absolute limit specified in Table 6.7.3.5.2-4a of TS 38.141-2 [2].

### **4.4 OTA Transmitter spurious emissions**

#### **4.4.1 OTA transmitter spurious emissions BS type 1-O**

For Category A BS the TRP of any spurious emission shall not exceed the limits in Table 6.7.5.2.5.1-1 in TS 38.141-2 [2]. For Category B BS the TRP of any spurious emission shall not exceed the limits in Table 6.7.5.2.5.1-2 in TS 38.141-2 [2].

#### 4.4.2 OTA transmitter spurious emissions BS type 2-O

For Category A BS the power of any spurious emission shall not exceed the limits in Table 6.7.5.2.5.2.2-1 in TS 38.141-2 [2]. For Category B BS the power of any spurious emission shall not exceed the limits in Table 6.7.5.2.5.2.2-2 in TS 38.141-2 [2].

#### 4.4.3 Protection of the BS receiver of own or different BS

This requirement shall be applied for NR FDD operation in order to prevent the receivers of own or a different BS of the same band being desensitised by emissions from a BS type 1-O.

This requirement is a co-location requirement as defined in clause 4.9, in TS 38.104 [6]. The power levels are specified at the CLTA output, as described in 4.12.2 of TS 38.141-2 [2].

The total power of any spurious emission from both polarizations of the CLTA connector output shall not exceed the limits in Table 6.7.5.3.5.1-1 in TS 38.141-2 [2].

#### 4.4.4 Additional spurious emissions requirements

In certain regions the following additional requirements in TS 38.141-2 [2] may apply:

For BS co-existence with systems operating in other frequency bands, the requirement in Table 6.7.5.4.5-1.

For protection of PHS, the requirement in Table 6.7.5.4.5-2

For BS operating in Band n50 and n75 within 1432-1452 MHz, and in Band n51 and Band n76, the requirement in Table 6.7.5.4.5-3.

For BS operating in NR Band n50 and n75 within 1492-1517 MHz, and in Band n74 within 1492-1518 MHz, the requirements in Table 6.7.5.4.5-4.

For BS operating in Band n13 and n14 to ensure that appropriate interference protection is provided to 700 MHz public safety operations, the requirements in Table 6.7.5.4.5-5.

For BS operating in Band n30, the requirements in Table 6.7.5.4.5-6.

For BS operating in Band n26 to ensure that appropriate interference protection is provided to 800 MHz public safety operations, the requirements in Table 6.7.5.4.5-7.

For BS operating in Band n41 and n90 operation in Japan, the requirements in Table 6.7.5.4.5-8.

The following additional requirement shall apply:

For BS operating in the frequency range 24.25 – 27.5 GHz, for protection of Earth Exploration Satellite Service, the requirements in Table 6.7.5.4.5.2-1 of TS 38.141-2 [2].

#### 4.4.5 Co-location requirements

These requirements may be applied for the protection of other BS receivers when GSM900, DCS1800, PCS1900, GSM850, CDMA850, UTRA FDD, UTRA TDD, E-UTRA and/or NR BS are co-located with a BS.

The requirements assume co-location with base stations of the same class.

NOTE: For co-location with UTRA, the requirements are based on co-location with UTRA FDD or TDD base stations.

This requirement is a co-location requirement as defined in clause 4.9, in TS 38.104 [6]. The power levels are specified at the CLTA output, as described in 4.12.2 of TS 38.141-2 [2].

The output of the CLTA of any spurious emission shall not exceed the test limit in Table 6.7.5.5.5.1-1 in TS 38.141-2 [2].



For a multi-band RIB, the exclusions and conditions in the notes column of Table 6.7.5.5.1-1 apply for each supported operating band.

#### **4.5 OTA receiver spurious emissions**

##### **4.5.1 OTA receiver spurious emissions BS type 1-O**

The receiver spurious emissions for BS type 1-O at RIB interface shall be below the applicable limits defined in Table 7.7.5.1-1 of TS 38.141-2 [2].

##### **4.5.2 OTA receiver spurious emissions BS type 2-O**

The receiver spurious emissions for BS type 2-O at RIB interface shall be below the applicable limits defined in table 7.7.5.2-1 of TS 38.141-2 [2], with the step frequencies defined in Table 7.7.5.2-2 of TS 38.141-2 [2]. In addition, the requirement to protect Earth Exploration Satellite Service shall apply for BS operating in the frequency range 24.25 – 27.5 GHz, as defined in Table 7.7.5.2-3 of TS 38.141-2 [2].

## **5 References**

- [1] 3GPP TS 38.141-1 V17.6.0 (2022-06), “3rd Generation Partnership Project; Technical Specification Group Radio Access Network; NR; Base Station (BS) conformance testing Part 1: Conducted conformance testing (Release 17)”.
- [2] 3GPP TS 38.141-2 V17.6.0 (2022-06), “3rd Generation Partnership Project; Technical Specification Group Radio Access Network; NR; Base Station (BS) conformance testing Part 2: Radiated conformance testing (Release 17)”.
- [3] Recommendation ITU-R SM.329: "Unwanted emissions in the spurious domain".
- [4] Recommendation ITU-R M.1545: "Measurement uncertainty as it applies to test limits for the terrestrial component of International Mobile Telecommunications-2000".
- [5] 3GPP TS 37.213 v17.2.0 (2022-06), “3rd Generation Partnership Project; Technical Specification Group Radio Access Network; Physical layer procedures for shared spectrum channel access (Release 17)”.
- [6] 3GPP TS 38.104 V17.6.0 (2022-06), “3rd Generation Partnership Project; Technical Specification Group Radio Access Network; NR; Base Station (BS) radio transmission and reception (Release 17)”.

## **Attachment 1 to Annex 2**

### **Definition of test tolerance**

#### **Test tolerance**

With reference to Recommendation ITU-R M.1545 [4], “test tolerance” is the relaxation value referred to in recommends 2 of Recommendation ITU-R M.1545, i.e., the difference between the core specification value and the test limit, evaluated applying the shared risk principle as per Figure 2 and Figure 3 of Annex 2 of Recommendation ITU-R M.1545. In case the core specification value is equal to the test limit (Figure 3 of Annex 2 of Recommendation ITU-R M.1545) the “test tolerances” are equal to 0 dB.

## Annex 3

## 5Gi RIT

Source: Document [5D/1380](#)

## Annex X

# DECT-2020 NR - RIT Component

## 1 Introduction

This Annex provides the generic unwanted emission characteristics of base stations (radio equipment in FT-mode) using the DECT-2020 NR radio interface.

## 2 Transmitter spectrum emission requirements for DECT-2020

### 2.1 General

Radio equipment transmitter spectrum emissions are occupied channel emissions, out of band and spurious emissions. The relation of these emission components is illustrated in Figure 2.1-1.

The transmitter characteristics are specified at the antenna connector(s) of the radio equipment. For radio equipment with an integral antenna only, a reference antenna(s) with a gain of 0 dBi should be assumed for each antenna port(s).

*[Editor's note: Reference point for AAS needs to be clarified. AAS are not used in DECT-2020 at this point.]*

FIGURE 2.1-1

Transmitter RF spectrum

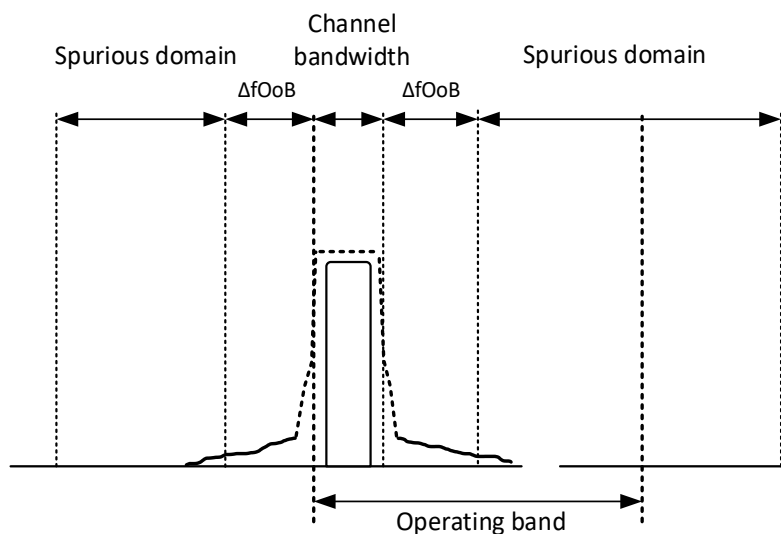

## 2.2 Occupied channel BW

The occupied bandwidth is the width of a frequency band such that, below the lower and above the upper frequency limits, the mean powers emitted are each equal to a specified percentage  $\beta/2$  of the total mean transmitted power.

The value of  $\beta/2$  shall be taken as 0.5%.

The occupied bandwidth shall be less than the nominal channel bandwidth as defined in Table 2.2-1.

TABLE 2.2-1

Channel bandwidth

Parameter	Operating channel bandwidth I	Operating channel bandwidth II	Operating channel bandwidth III
Nominal channel bandwidth (MHz)	1.728	3.456	6.912
Transmission channel bandwidth (MHz)	1.539	3.051	6.075

## 2.3 Out of band emissions

The out-of-band emissions are unwanted emissions immediately outside the assigned channel bandwidth resulting from the modulation process and non-linearity in the transmitter but excluding spurious emissions.

The spectrum emission mask of the radio device (RD) applies to frequencies ( $\Delta f_{OOB}$ ) starting from the  $\pm$  edge of the assigned channel. For frequencies offset greater than  $\Delta f_{OOB}$  as specified in Tables 2.3-1, 2.3-2 and 2.3-3, the spurious requirements in clause 2.4 are applicable.

TABLE 2.3-1

Spectrum emission limit for 1.728 MHz channel bandwidth

Spectrum emission limit (dBm)		
$\Delta f_{OOB}$ / MHz	1.728 MHz channel bandwidth	Measurement bandwidth
$\pm 0$ to 0.094 5	-10	30 kHz
$\pm 0.094$ 5 to 1.633 5	-10	1 MHz
$\pm 1.633$ 5 to 1.822 5	-13	1 MHz
$\pm 1.822$ 5 to 3.361 5	-20	1 MHz
$\pm 3.361$ 5 to 3.456	-23	1 MHz

TABLE 2.3-2

**Spectrum emission limit for 3.456 MHz channel bandwidth**

<b>Spectrum emission limit (dBm)</b>		
$\Delta f_{OOB}$ / MHz	<b>3.456 MHz channel bandwidth</b>	<b>Measurement bandwidth</b>
±0 to 0.202 5	-10	30 kHz
±0.202 5 to 3.253 5	-10	1 MHz
±3.253 5 to 3.658 5	-13	1 MHz
±3.658 5 to 6.709 5	-20	1 MHz
±6.709 5 to 6.912	-23	1 MHz

TABLE 2.3-3

**Spectrum emission limit for 6.912 MHz channel bandwidth**

<b>Spectrum emission limit (dBm)</b>		
$\Delta f_{OOB}$ / MHz	<b>6.912 MHz channel bandwidth</b>	<b>Measurement bandwidth</b>
±0 to 0.418 5	-10	30 kHz
±6.493 5 to 7.330 5	-13	1 MHz
±7.330 5 to 13.405 5	-20	1 MHz
±13.405 5 to 13.824	-23	1 MHz

## 2.4 Spurious emissions

Spurious emissions are emissions which are caused by unwanted transmitter effects such as harmonics emission, parasitic emissions, intermodulation products and frequency conversion products, but exclude out of band emissions unless otherwise stated. The spurious emission limits are specified in terms of general requirements in-line with Recommendation ITU-R SM.329.

Unless otherwise stated, the spurious emission limits apply for the frequency ranges that are more than  $F_{OOB}$  (MHz) in Table 2.3-1 from the edge of the channel bandwidth. The spurious emission limits in Table 2.4-1 apply for all transmitter bands and channel bandwidths.

TABLE 2.4-1

**Spurious emission limits**

<b>Frequency range</b>	<b>Maximum level</b>	<b>Measurement bandwidth</b>
$9 \text{ kHz} \leq f < 150 \text{ kHz}$	-36 dBm	1 kHz
$150 \text{ kHz} \leq f < 30 \text{ MHz}$	-36 dBm	10 kHz
$30 \text{ MHz} \leq f < 1\,000 \text{ MHz}$	-36 dBm	100 kHz
$1 \text{ GHz} \leq f < 12,75 \text{ GHz}$	-30 dBm	1 MHz
$12,75 \text{ GHz} \leq f < 5^{\text{th}}$ harmonic of the upper frequency edge in GHz	-30 dBm	1 MHz