

Radiocommunication Study Groups



Source: Annexure-3.7 of the Chairman 51st WP-5D Report

Document-5D/C-xxxx

15 May 2026

English only

IAFI¹

**PROPOSAL FOR ELEVATION OF WORKING DOCUMENT TOWARDS A
PRELIMINARY DRAFT REVISION OF REPORT ITU-R M.2480**

**National approaches of some countries on the implementation of terrestrial
IMT systems in bands identified for IMT**

¹ IAFI is a sector Member of ITU-R. For more details, please see <https://iafi.in>

Background

During the 51st WP 5D meeting, WG General Aspects proposed elevating the Working Document towards a Preliminary Draft Revision of Report ITU-R M.2480, “National approaches of some countries on the implementation of terrestrial IMT systems in bands identified for IMT,” to the status of a Preliminary Draft Revision of the Report.

While several members supported this elevation, concerns were raised by some delegates regarding the procedural necessity of the Plenary reviewing the document prior to changing its status. Due to the document's extensive length (68 pages) and the limited time available during the meeting for a comprehensive review of the WG General Aspects' output, the Chairman of WP 5D decided to retain its status as a Working Document for the interim. Consequently, the document was carried forward to the 52nd WP 5D meeting as a Working Document and attached as Annex 3.7 to the Chairman's Report of the 51st WP 5D meeting.

Discussions

The work to update Report ITU-R M.2480 was initiated during the 44th ITU-R WP 5D meeting. The updated report covers critical aspects such as spectrum utilization, throughput delivered, and usage scenarios realized across various environments, including dense urban areas, hotspots, and indoor settings, in multiple countries.

A total of 16 Member States has submitted case studies to update this report. All of the national approaches and subsequent updates submitted by the various Member States have been duly incorporated into this revision.

Proposal

IAFI proposes that the Working Document regarding the revision of Report ITU-R M.2480-1 be elevated to Preliminary Draft Revision of Report (PDRR) status during the 52nd WP 5D meeting. Annexure-3.7 of the 51st WP-5D Chairman Report is attached as Annexure-1.

Annexure-1

Annexure-3.7 of the 51ST WP5D Chairman Report

[WORKING DOCUMENT TOWARDS A] PRELIMINARY DRAFT
REVISION OF REPORT ITU-R M.2480-1

National approaches of some countries on the implementation of terrestrial IMT systems in bands identified for IMT²

{Editor's Note: Index of the document will be compiled after finalizing all changes}.

TABLE OF CONTENTS

	<i>page</i>
1 Introduction and additional considerations	4

² The Administration of the Russian Federation does not support the approval of this Report. The Report in its current form contains some information that is not relevant to its scope, e.g. description of the auctions principles that are studied by ITU-R SG 1. Moreover, this Report does not sufficiently address some important technical and regulatory aspects, e.g. experience on compatibility of IMT systems with other services and on application of RR No **9.21** when introducing IMT.

2	Relevant ITU-R Recommendations and Reports	5
3	Structure of the Annexes <u>6</u>	
	Annex 1 – Canada Canadian approaches on the use of terrestrial IMT systems in frequency bands below 1 GHz identified for IMT	8
	A1.2 The 700 MHz band	9
	A1.3 The 600 MHz band	10
	Annex 2 – Germany Approaches on the 1 800 MHz band for LTE	11
	A2.1 Introduction	11
	A2.2 Frequency auctions	12
	A2.3 Introduction of LTE in the 1 800 MHz band	15
	Annex 3 – Iran Iran approach to terrestrial IMT deployment (LTE EMBMS) in the 1 800 MHz band	15
	A3.1 Introduction	15
	A3.2 Approach	16
	A3.3 Conclusion	17
	Annex 4 – Japan A national approach to terrestrial IMT in 700 MHz band: Japan approach	17
	A4.1 Introduction	17
	A4.2 Sharing and coexisting studies for the transition	17
	A4.3 Approach	18
	Annex 5 – Mexico National approaches on IMT implementation in the 600 MHz and 700 MHz frequency bands	19
	A5.1 Introduction	19
	A5.2 National approaches	19
	A5.3 Conclusion	21
	Annex 6 – United States of America Approach on the use of terrestrial IMT systems in frequency bands below 1 GHz identified for IMT	21
	A6.1 Introduction	21
	A6.2 600 MHz	22
	A6.3 700 MHz	27
	Annex 7 – United States of America Approach on the planning and implementation of terrestrial IMT systems in the frequency band 3 550-3 700 MHz	28
	A7.1 Introduction	28
	A7.2 Access Model and Band Plan	29

A7.3 Operations near international borders	31
A7.4 Spectrum Access System	31
Annex 8 – Tunisia A national approach on IMT deployment in the 700 MHz frequency band	32
A8.1 Introduction	32
A8.2 Tunisian approach	33
Annex 9 – India: National approach on IMT deployment	35
A9.1 Introduction	35
A9.2 Approach	35
A9.3 Enhancing spectrum availability for IMT systems in India	36
A9.4 National Telecom Policy (NTP), 2012	36
A9.5 National Digital Communications Policy (NDCP), 2018	36
A9.6 Making bands contiguous	38
A9.7 Subscriber base	38
A9.8 Network deployments and accessibility	39
Annex 10 – France: National field report on the introduction of IMT in the 800 and 700 MHz bands	42
A10.1 Introduction	42
A10.2 800 MHz band. The Digital Dividend	42
A10.3 700 MHz band	44
A10.4 Conclusions	46
Annex 11 – Brazil: Conclusion of the first stage of the Brazilian analogue television switch-off and the use of the 700 MHz band for IMT	46
A11.1 Introduction	46
A11.2 First stage results	47
A11.3 Next steps	47
A11.4 Conclusion	48
Annex 12 – China: A national approach to terrestrial IMT deployment in 3 400-3 600 MHz band	48
A12.1 Introduction	48
A12.2 Frequency allocation of C band in China	48
A12.3 Sharing and coexistence in this band	49

1 Introduction and additional considerations

The Annexes to this Report provide national approaches taken and/or knowledge gained by certain countries wishing to share their approaches, in the use/deployment or planning of terrestrial component of International Mobile Telecommunications (IMT)³ in certain frequency bands that are allocated to the mobile service and identified for IMT, which includes regulatory, technical and operational aspects.

This Report is not intended to be used as a basis for any potential World Radiocommunication Conference decision. It is emphasized that any use/deployment of IMT should be in conformity with the Radio Regulations.

These Annexes reflect the national policy of the contributing Members States in regard with use and/or deployment of IMT in their countries, they do not therefore necessarily reflect the national policy and other important aspects relating to the use and deployment of IMT in other countries. It is also assumed that regulatory and technical aspects reflected in the Radio Regulations applicable to the IMT identifications in the contributing Member States should be taken into account while considering the approaches provided. The approaches and viewpoints presented may not be applicable in countries without such identifications. Consequently, these annexes should be considered for informational purposes only.

It is also noted that some other aspects relating to the deployment and operation of IMT are not covered in this Report and may be found in other ITU-R documents. In particular for additional information related to compatibility and sharing between IMT and other systems, administrations are invited to take into account the results of relevant studies made in ITU-R.

The dissemination of the information contained in the Annexes to this Report may be useful to other Member States to consider in their future use/deployment of IMT.

Given the importance to clearly understand the information provided on national approaches taken and/or knowledge gained by certain countries in the deployment of terrestrial IMT systems, related to technical, operational and regulatory/procedural aspects, it should be understood that the following considerations were noted:

- The Annexes may include information of IMT networks from the planning stages to actual deployments of IMT radio stations. The presentation of the results of technical operation of networks, deployment scenarios and other technical information are useful parts of national approaches and included where available.
- This Report is not linked to any specific frequency band and may be applied to any frequency band identified for IMT in order to increase the number of cases and encourage Member States to share their approaches and/or knowledge gained in IMT deployment with other Members States. Each Annex reflects the viewpoint of the contributing Member State.
- It is appropriate to report on the results of achieving co-existence with other services, solutions on the use of spectrum in border areas, including the cross-border coordination, and the approaches and/or knowledge gained in applying regulatory obligations and restrictions arising from the provisions of the Radio Regulations.
- Consideration of information of commercial or economic substance is outside scope of this Report. It is also in conformity with objectives and purposes of CV 155. However, such information may be presented if this complements the information on national approaches and/or knowledge gained relating to the scope of this technical report.

³ See also Resolution [ITU-R 56](#) – Naming for International Mobile Telecommunications.

It should be noted that there may be additional aspects which could be considered when using the content of these annexes, including other regulatory or technical aspects. It is expected that administrations may contribute to this Report in the future to update their approaches and/or knowledge gained.

2 Relevant ITU-R Recommendations and Reports

- Recommendation [ITU-R M.1036](#) – Frequency arrangements for implementation of the terrestrial component of International Mobile Telecommunications (IMT) in the bands identified for IMT in the Radio Regulations
- Recommendation [ITU-R SM.1047](#) – National spectrum management
- Report [ITU-R SM.2012](#) – Economic aspects of spectrum management
- Report [ITU-R SM.2015](#) – Methods for determining national long-term strategies for spectrum utilization
- Report [ITU-R M.2030](#) – Coexistence between IMT-2000 time division duplex and frequency division duplex terrestrial radio interface technologies around 2 600 MHz operating in adjacent bands and in the same geographical area
- Report [ITU-R M.2031](#) – Compatibility between WCDMA 1800 downlink and GSM 1900 uplink
- Report [ITU-R M.2038](#) – Technology trends
- Report [ITU-R M.2041](#) – Sharing and adjacent band compatibility in the 2.5 GHz band between the terrestrial and satellite components of IMT-2000
- Report [ITU-R M.2045](#) – Mitigating techniques to address coexistence between IMT-2000 time division duplex and frequency division duplex radio interface technologies within the frequency range 2 500-2 690 MHz operating in adjacent bands and in the same geographical area
- Report [ITU-R M.2072](#) – World mobile telecommunication market forecast
- Report [ITU-R M.2078](#) – Estimated spectrum bandwidth requirements for the future development of IMT-2000 and IMT-Advanced
- Report [ITU-R M.2109](#) – Sharing studies between IMT-Advanced systems and geostationary satellite networks in the fixed-satellite service in the 3 400-4 200 MHz and 4 500-4 800 MHz frequency bands
- Report [ITU-R M.2110](#) – Sharing studies between radiocommunication services and IMT systems operating in the 450-470 MHz band
- Report [ITU-R M.2113](#) – Report on sharing studies in the 2 500-2 690 MHz band between IMT-2000 and fixed broadband wireless access systems including nomadic applications in the same geographical area
- Report [ITU-R M.2320](#) – Future technology trends of terrestrial IMT systems
- Report [ITU-R M.2324](#) – Sharing studies between potential International Mobile Telecommunication systems and aeronautical mobile telemetry systems in the frequency band 1 429-1 535 MHz
- Report [ITU-R M.2336](#) – Consideration of the frequency bands 1 375-1 400 MHz and 1 427-1 452 MHz for the mobile service – Compatibility with systems of the Earth exploration-satellite service within the 1 400-1 427 MHz frequency band

Report [ITU-R M.2373](#) – Audio-visual capabilities and applications supported by terrestrial IMT systems

Report [ITU-R M.2374](#) – Coexistence of two TDD networks in the 2 300-2 400 MHz band

Report [ITU-R M.2375](#) – Architecture and topology of IMT networks

Report [ITU-R BT.2301](#) – National field reports on the introduction of IMT in the bands with co primary allocation to the broadcasting and the mobile services

Report [ITU-R BT.2337](#) – Sharing and compatibility studies between digital terrestrial television broadcasting and terrestrial mobile broadband applications, including IMT, in the frequency band 470-694/698 MHz

Report [ITU-R BT.2339](#) – Co-channel sharing and compatibility studies between digital terrestrial television broadcasting and international mobile telecommunication in the frequency band 694-790 MHz in the GE06 planning area

Report [ITU-R SM.2353](#) – The challenges and opportunities for spectrum management resulting from the transition to digital terrestrial television in the UHF bands

Report [ITU-R S.2368](#) – Sharing studies between International Mobile Telecommunication-Advanced systems and geostationary satellite networks in the fixed-satellite service in the 3 400-4 200 MHz and 4 500-4 800 MHz frequency bands in the WRC study cycle leading to WRC-15.

3 Structure of the Annexes

Annex	Country	Title
1	Canada	Canadian approaches on the use of terrestrial IMT systems in frequency bands below 1 GHz identified for IMT
2	Germany	Approaches on the 1 800 MHz band for LTE
3	Iran	Iran approach to Terrestrial IMT deployment (LTE EMBMS) in the 1 800 MHz Band
4	Japan	A national approach to terrestrial IMT in 700 MHz band: Japan approach
5	Mexico	National approaches on IMT implementation in the 600 MHz and 700 MHz frequency bands
6	United States of America	Approaches on the use of terrestrial IMT systems in frequency bands below 1 GHz identified for IMT
7	United States of America	Approaches on the planning and implementation of terrestrial IMT systems in the frequency band 3 550-3 700 MHz
8	Tunisia	A National Approach on IMT Deployment in the 700 MHz Frequency Band
9	India	National Approaches on IMT deployment
10	France	National field report on the introduction of IMT in the 800 and 700 MHz bands
11	Brazil	Conclusion of the first stage of the Brazilian analogue television switch-off and the use of the 700 MHz band for IMT
12	China	National approaches of some countries on the implementation of terrestrial IMT systems in bands identified for IMT

Annex 1

Canada

Canadian approaches on the use of terrestrial IMT systems in frequency bands below 1 GHz identified for IMT

A1.1 Introduction

In Canada, spectrum allocations are generally technology neutral. Most spectrum bands used for commercial mobile in Canada are bands identified for IMT in order to take advantage of harmonization and equipment economies of scale. Since the 1980s, 824-849/869-894 MHz (50 MHz) has been used for commercial cellular systems, 806-824/851-869 MHz for Land Mobile Radio (LMR), and 849-851/894-896 MHz for Air-Ground. The bands 777-782 MHz and 746-751 MHz were made available for commercial mobile use through an auction process in 2015, followed by another auction process for 613-698 MHz in 2019. As of June 2019, a total of 718 MHz of spectrum has been made available for commercial mobile, of which 188 MHz is below 1 GHz.

By 2017, the percentage of Canadians with access to long-term evolution (LTE) and long-term evolution advanced (LTE-A) had grown to 99% and 92% respectively. In 2016, the most recent period for which data is available, slightly more households subscribed to mobile services (87.9%) than Internet services (87.4%). Nearly all Canadian households (99.3%) subscribed to either mobile or landline service in 2016, and households owned on average 1.6 mobile phones. Over the last decade, the percentage of households with landlines has decreased, while the percentage with mobile phones has increased. Fewer households are subscribing to both services – in 2016, almost a third (32.5%) of Canadian households were mobile-only households, and 11.4% were landline-only⁴.

A1.1.1 Addressing the need for more mobile spectrum in Canada

Innovation, Science and Economic Development (ISED), the organization responsible for spectrum management in Canada, continuously reviews the use of and need for additional spectrum for mobile services domestically. In Canada, data usage for mobile devices is growing, and mobile data traffic is expected to grow 7-fold from 2016 to 2021, a compound annual growth rate of 47%⁵.

Canada most recently reviewed the use of and need for additional spectrum for mobile as part of a consultation process concluding with the publication of the *Spectrum Outlook 2018 to 2022*⁶, released in June 2018. This document set out Canada's overall approach and planning activities related to the release of spectrum for commercial mobile services, as well licence-exempt applications, satellite services and wireless backhaul services over the years 2018 to 2022. In discussing future spectrum releases, the Spectrum Outlook assigned a priority level to each frequency band that indicated ISED's general approach to its potential release.

⁴ CRTC's 2018 Communications Monitoring Report, Section 1.2, <https://crtc.gc.ca/eng/publications/reports/policymonitoring/2018/cmr1.htm#s10ii1>

⁵ Cisco Visual Networking Index Mobile Forecast Highlights, 2016-2021, February 2017, http://www.cisco.com/c/dam/assets/sol/sp/vni/forecast_highlights_mobile/index.html

⁶ Spectrum Outlook 2018 to 2022, June 2018, <https://www.ic.gc.ca/eic/site/smt-gst.nsf/eng/sf11403.html>

In terms of frequency bands below 1 GHz, the Spectrum Outlook identified the 600 MHz (614-698 MHz) band as a high priority for commercial mobile service, indicating that it would be made available in 2019. In April 2019, ISED concluded its auction of the spectrum in the 600 MHz band. This process is further discussed in § A1.3.

The Spectrum Outlook also indicated that two other bands below 1 GHz, 814-824 MHz/859-869 MHz and 896-960 MHz, are being studied and monitored respectively, for the potential of future commercial mobile use. It should be noted that, in addition to the above, the Spectrum Outlook identified other spectrum above 1 GHz for potential commercial mobile use.

A1.2 The 700 MHz band

In preparation for the digital TV (DTV) transition, the CRTC announced in 2010 its decision⁷ to clear the 700 MHz band of all full-power analogue broadcasting transmitters by 31 August 2011. This transition took place as scheduled.

As early as 30 November 2010, Industry Canada (now ISED) initiated a consultation on a policy and technical framework to auction spectrum in the band 698-806 MHz (also known as the 700 MHz band), as announced in Canada Gazette Notice No. SMSE-018-10 “Consultation on a Policy and Technical Framework for the 700 MHz Band and Aspects Related to Commercial Mobile Spectrum”. Comments were sought on general policy considerations related to commercial mobile broadband spectrum use, competition issues and on the use of the 700 MHz band, as well as comments on spectrum use for public safety broadband applications. The results of this initial consultation are available in the following link:

<https://www.ic.gc.ca/eic/site/smt-gst.nsf/eng/sf09949.html>.

The decisions were subsequently announced in March 2012 in Canada Gazette Notice No. SMSE-002-12 “Policy and Technical Framework Mobile Broadband Services (MBS) – 700 MHz Band”. A “Consultation on a Licensing Framework for Mobile Broadband Services (MBS) – 700 MHz” Band was held in 2012, as announced in Canada Gazette Notice No. DGSO-002-12. This was followed by the “Licensing Framework for Mobile Broadband Services (MBS) – 700 MHz Band” in DGSA-001-13 (March 2013), which sets out the rules and procedures for participation in the competitive licensing process for spectrum in the 700 MHz band.

In the band 768-776/798-806 MHz, 16 MHz is designated for narrowband and wideband Public Safety; 20 MHz (758-768/788-798 MHz) has been designated for broadband Public Safety use in June 2017; both are aligned with U.S. Public Safety.

The successful bidders of mobile broadband spectrum in 698-716/728-746 MHz were awarded licences in February 2014. Following the emergence of an ecosystem of infrastructure equipment, as well as end user devices with multiband capability, operators started deployment of mobile services in the 700 MHz band throughout the country. As of January 2017, mobile broadband services using 700 MHz are widely available in most parts of Canada, as required by the deployment requirements attached to the licences. By leveraging the favourable propagation and penetration characteristics of low-band spectrum, these 700 MHz networks provide a platform for extending the reach of LTE-Advanced technology across both urban and rural markets and for enabling enhanced service offerings (such as VoLTE and eMBMS) to the customer.

A1.3 The 600 MHz band

Traditional users of the 600 MHz band include OTA TV broadcasting, remote rural broadband systems (RRBS), low-power apparatus (e.g. wireless microphones and camera systems), TV white

⁷ For further information regarding the CRTC decision, refer to the [Broadcasting Regulatory Policy CRTC 2010-167](#)

space (TVWS) devices and wireless medical telemetry systems (WMTS). This spectrum is also used for radio astronomy service (RAS) (band 608-614 MHz).

In its August 2015 Decision on Repurposing the 600 MHz Band, ISED announced that it would be jointly repurposing the 600 MHz band with the United States to include commercial mobile use by repacking over-the-air (OTA) TV broadcasting stations into lower frequencies. As part of this process, ISED is reconfiguring spectrum use in the bands by repurposing a portion of contiguous spectrum for use by mobile broadband services beginning with channel 51 and extending downward to channel 37. ISED completed its auction of this band for Commercial Mobile use on 4 April 2019⁸.

The Band Plan consists of seven paired 5+5 MHz downlink and uplink blocks, from 614-698 MHz which includes an 11 MHz duplex gap and a 3 MHz guard band, as per the following figure below, which follows the CITEL Recommendation PCC.II/REC. 56 (XXX-17)⁹ “Frequency arrangements for the terrestrial component of IMT in the band 614-698 MHz”.



The corresponding frequency arrangement is as follows:

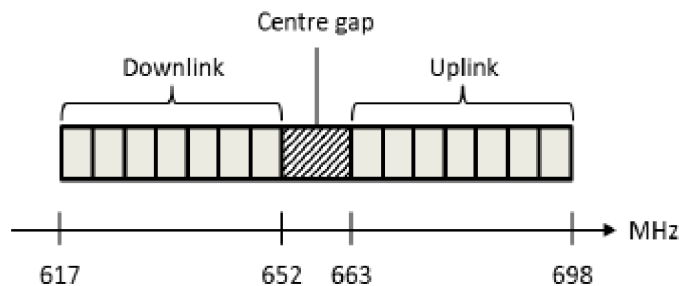

ISED has taken the necessary steps towards the transition of the band to commercial mobile following the guidelines in ITU-R Recommendations and Reports on spectrum management¹⁰. The following regulatory aspects should be noted:

- Decision on a Technical, Policy and Licensing Framework for Spectrum in the 600 MHz Band – see <http://www.ic.gc.ca/eic/site/smt-gst.nsf/eng/sf11372.html> and <http://www.ic.gc.ca/eic/site/smt-gst.nsf/eng/sf11374.html>.
- The 600 MHz frequency band is also used by wireless microphones and white space devices. For related decisions on wireless microphones and white space – see

⁸ http://www.ic.gc.ca/eic/site/smt-gst.nsf/eng/h_sf11331.html

⁹ <http://www.oas.org/citeldocuments/Download.aspx?id=4928>

¹⁰ In particular, Recommendation [ITU-R SM.1047](#), Report [ITU-R BT.2301](#), Report [ITU-R SM.2012](#), Report [ITU-R SM.2015](#) and Report [ITU-R SM.2353](#).

<http://www.ic.gc.ca/eic/site/smt-gst.nsf/eng/sf11491.html>. These decisions respectively address spectrum utilization by white space devices in the VHF and UHF ranges, and wireless microphones in the UHF and SHF ranges. The intent is twofold:

- updating the technical and policy framework for the use of white space devices; see Decision on the Technical and Policy Framework for White Space Devices (<http://www.ic.gc.ca/eic/site/smt-gst.nsf/eng/sf11486.html>); and
- updating the technical, policy and licensing framework for wireless microphones; see Decision on the Technical, Policy and Licensing Framework for Wireless Microphones (<http://www.ic.gc.ca/eic/site/smt-gst.nsf/eng/sf11490.html>).

- Spectrum Advisory Bulletin (SAB) related to the wireless microphones and white space transition – see <http://www.ic.gc.ca/eic/site/smt-gst.nsf/eng/sf11341.html>.

This spectrum advisory bulletin (SAB) serves to notify radio equipment suppliers and users of low-power radio apparatus – including wireless microphones – capable of operating in the frequency range 614-698 MHz of changes to certification and operations.

Annex 2

Germany

Approaches on the 1 800 MHz band for LTE

A2.1 Introduction

The 1 800 MHz band (1 710-1 785 MHz/1 805-1 890 MHz) has been identified for IMT long time ago and was used by public mobile networks even before. In Germany, it was the second band after the 900 MHz-band that was used to introduce GSM services. The licenses for these bands were reserved for Europe-wide mobile communications services operating according to the GSM standard as a result of European harmonisation. A unique opportunity was therefore provided to introduce mobile communications across Europe. GSM licensing in Germany and the Europe-wide introduction of GSM mobile services enabled optimum use to be made of the potential of the 900 MHz- and 1 800 MHz-bands for both services and infrastructure competition. Economically, GSM has been a resounding success for the German mobile market with great importance for the economy as a whole. It also delivered great social benefit for consumers who, for the very first time, were offered nationwide mobile communications by the four operators in the market. Owing to its introduction across Europe the GSM success story can also be viewed in terms of economic and social integration in the European Union.

At the time of introduction in the 1990s only the parts 1 725-1 782 MHz and 1 820-1 877 MHz were available for the introduction of GSM services. The 1 800 MHz GSM licenses had historically different terms which were aligned in the process of the auctions described below. This alignment was necessary in order to ensure that the same regulatory framework conditions are applicable for all operators, as the licences would have ended at different times because of licence grant in stages. Different terms of the GSM licences would have made reallocation processes or spectrum re-award more difficult if, successively, only parts of all the 1 800 MHz band had been available.

This alignment created a regulatory environment allowing decisions on use of the entire spectrum after 2016 to be taken at the same time, suitably ahead of their expiry¹¹.

A2.2 Frequency auctions

A2.2.1 2010 auction

In 2010 an auction for Mobile/Fixed Communications Networks (MFCN) incl. IMT was held.

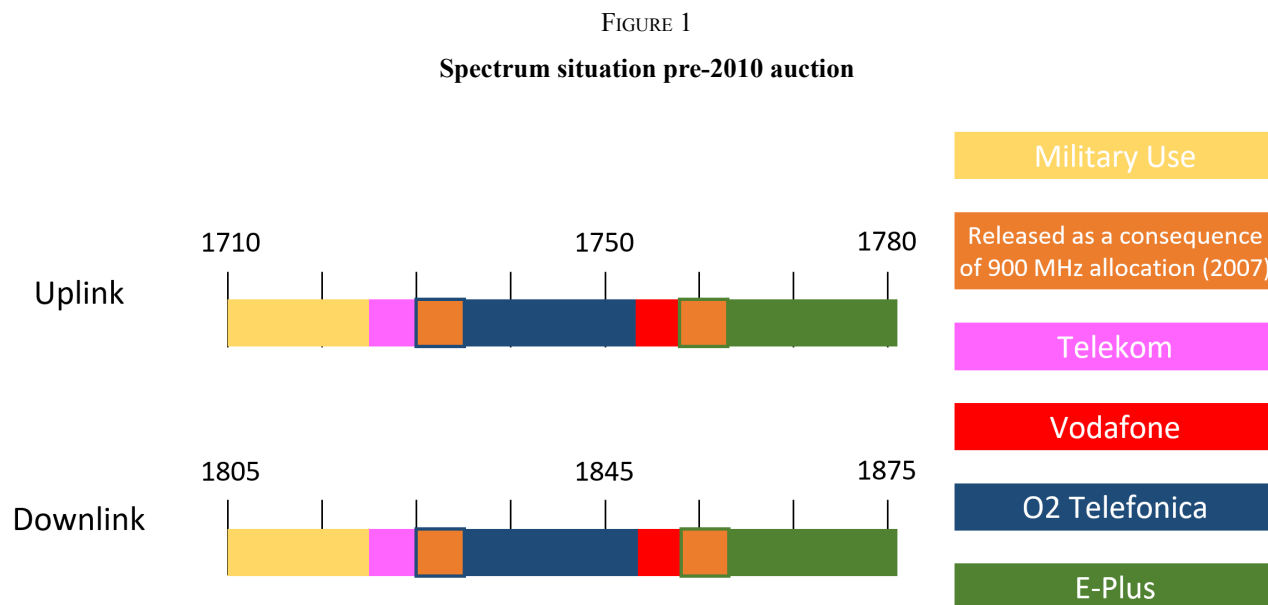

Figure 1 shows the spectrum situation before the auction. The green, blue, red and magenta colours indicate the IMT licence holders.

The yellow parts of 2×15 MHz were released from military use and were available for auction. An earlier extension of the 900 MHz GSM band allowed two operators (O2 Telefonica and E-Plus¹²) to get each 2×5 MHz in 900 MHz when returning 2×5 MHz in 1 800 MHz in 2007. These two blocks of 2×5 MHz in 1 800 MHz were also available for auction. For further information, see reference¹³.

¹¹ Bundesnetzagentur, Translation of Decision on Auction 2015, Available at: https://www.bundesnetzagentur.de/SharedDocs/Downloads/EN/BNetzA/Areas/Telecommunications/TelecomRegulation/FrequencyManagement/ElectronicCommunicationsServices/DecisionP2016_pdf.pdf?__blob=publicationFile&v=3V (accessed 27 Jan 2017).

¹² E-Plus is now part of Telefonica.

¹³ Bundesnetzagentur, Translation of Decision on Auction 2010, Available at: https://www.bundesnetzagentur.de/SharedDocs/Downloads/EN/BNetzA/Areas/Telecommunications/TelecomRegulation/FrequencyManagement/ElectronicCommunicationsServices/FrequencyAward2010/DecisionPresidentChamber101022.pdf?__blob=publicationFile&v=2 (accessed 27 Jan 2017).

FIGURE 2

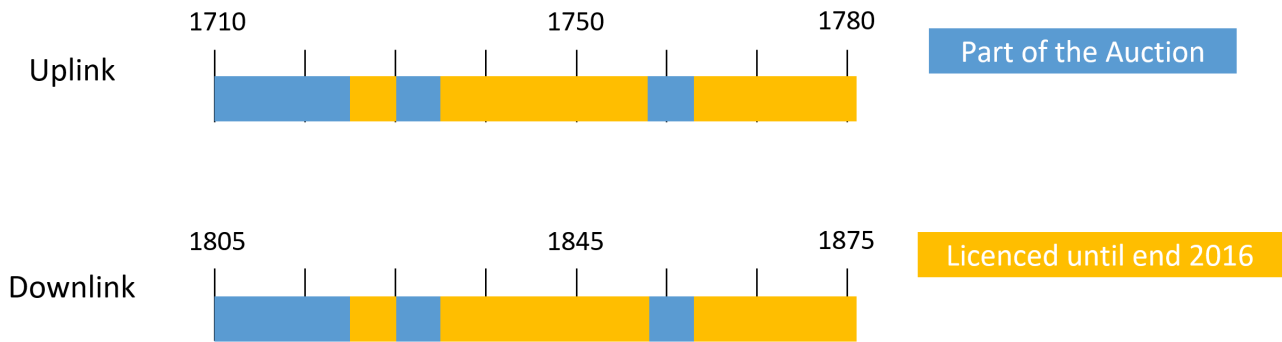
Spectrum available in the 2010 auction

The blue parts in Fig. 2 show the parts of the 1 800 MHz spectrum that were available in the 2010 auction which in total gave 2×25 MHz of spectrum for auction. The remaining parts shown in yellow were licensed until end 2016 and were therefore not part of the auction. The auction provided paired blocks of 5 MHz.

FIGURE 3

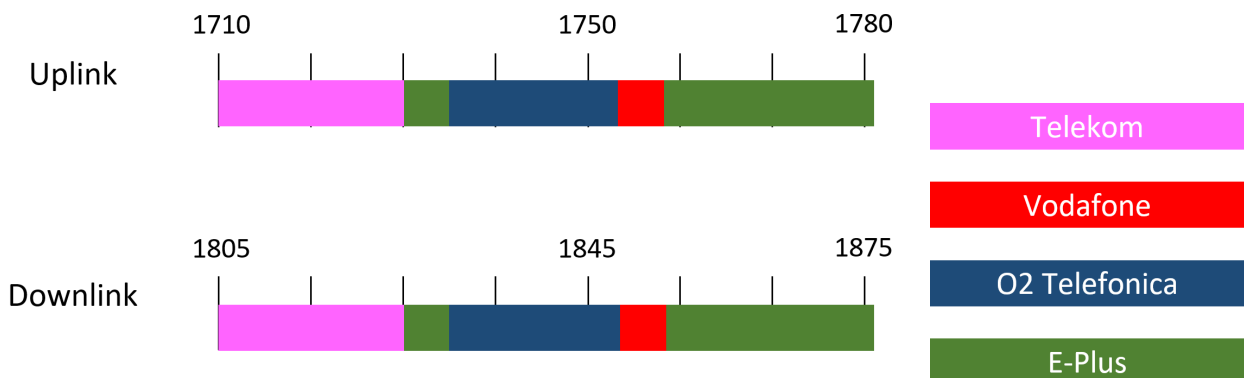
Spectrum situation post-2010 auction

The auction resulted in the following spectrum allocation as shown in Fig. 3. The new licenses were awarded on a technology neutral basis to allow for the introduction of LTE services. The technical restrictions on the not auctioned GSM blocks had been lifted in the wake of a flexibilization process. The 1 800 MHz-bands could then be used on a technology neutral basis and thus also for broadband systems such as LTE or LTE Advanced¹⁴. The license duration was set to 15 years, i.e. until end 2025.

¹⁴ Bundesnetzagentur, Translation of Decision on Flexibilisation (2009), Available at: https://www.bundesnetzagentur.de/SharedDocs/Downloads/EN/BNetzA/Areas/Telecommunications/TelecomRegulation/FrequencyManagement/FlexibilisationFrequency/DecisionPresidentChamberFlexibilisation101022pdf.pdf?__blob=publicationFile&v=2 (accessed 27 Jan 2017).

A2.2.2 2015 auction

Due to the expiry of the remaining licences at the end of 2016 the other parts were the subject of another auction in 2015.

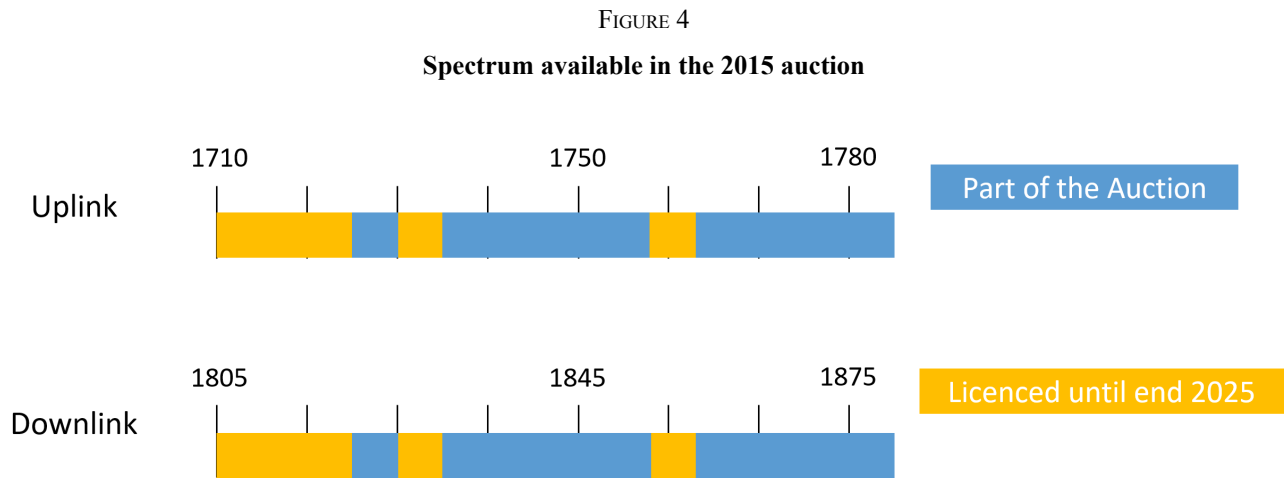

The blue parts in Fig. 4 show the parts of the 1 800 MHz spectrum that were available in the 2015 auction which in total gave 2×50 MHz of spectrum for auction. The remaining parts shown in yellow are licensed until end 2025 and were therefore not part of the auction. The auction provided paired blocks of 5 MHz. For further information, see reference¹⁵.

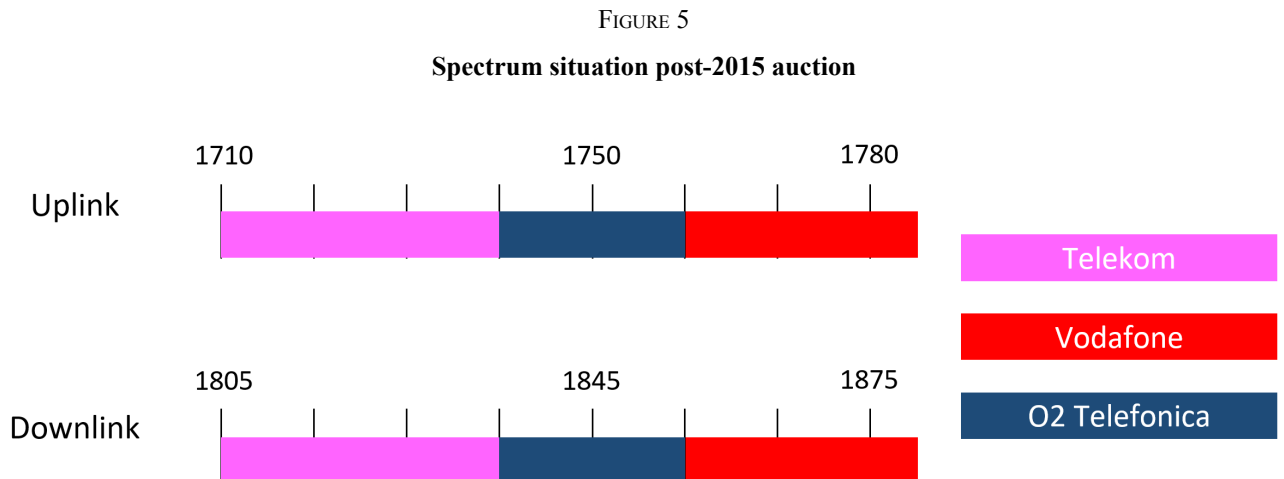

Figure 5 shows the result of the 2015 spectrum auction which included some reorganisation of two blocks of 2×5 MHz, in particular the block 1 758-1 763 MHz/1 853-1 858 MHz, that had been part of the previous auction. The new licenses were awarded for MFCN incl. IMT on a technology neutral basis which allowed the introduction of LTE services with a license duration of ten years, i.e. until end 2025. The timing was chosen in order to align the license duration in the whole band.

¹⁵ Bundesnetzagentur, Translation of Decision on Auction 2015.

A2.3 Introduction of LTE in the 1 800 MHz band

Following both auctions, operators subsequently started the rollout of LTE services in the band. It provides now valuable opportunities to improve LTE capacity particularly in urban areas.

Annex 3

Iran

Iran approach to terrestrial IMT deployment (LTE EMBMS) in the 1 800 MHz band

A3.1 Introduction

IMT systems have the potential to provide audio-visual services to users. The mobile industry is increasingly looking at evolved Multimedia Broadcast Multicast Service (eMBMS), an LTE embedded broadcast mode that could be used to serve a growing mobile video/TV consumption and other highly popular data services. It can be used to boost capacity for live and on-demand content such as popular websites, breaking news, etc. Apart from audiovisual services, eMBMS could potentially be used for other applications, such as software updates, magazine subscriptions, traffic and weather information update, map downloads, and many others. In current version of eMBMS (3GPP Rel-13), up to 60 percent of the FDD radio resources and up to 50 percent for TDD can be assigned to broadcast in an LTE network. This application can be implemented in any band identified for IMT and eMBMS does not address any specific band.

On the other hand, the assigned frequency band has a key feature role in IMT network deployment. Most LTE networks have been implemented in the 800 MHz, 1 800 MHz, 2 100 MHz and 2 600 MHz frequency bands. It is obvious that lower frequencies (800 MHz) offer advantages for coverage purposes as radio signals propagate in the environment farther than in higher frequency bands (1 800 MHz). It is also important to note that better propagation properties of the lower frequency bands allow signal coverage (including indoors) to be provided with fewer base stations, leading to economic benefits. However, the interfering signals also reach further in the lower than in the higher frequency bands. The cyclic prefix in current LTE eMBMS standard (i.e. 3GPP Release 13) limits an inter-site distance (ISD) to a maximum of (about) 10 km. At such short distances the advantages of lower frequencies over the higher frequency bands in terms of coverage are not significant. In addition, spectrum efficiency that can be achieved in eMBMS networks is strongly dependent on the Inter Site Distance (ISD). At ISD of about 10 km the achievable spectrum efficiency of eMBMS is in the order of 0.5 bits/s/Hz but can be much lower. Higher spectrum efficiency can only be achieved with smaller ISD hence further reducing potential benefits of the lower frequency ranges. Thus, lower frequencies are more suitable for rural and un-populated coverage.

On the other side, the higher frequency bands come with more capacity than lower frequency bands as they offer larger bandwidths and allow for more densification using smaller cells. Most usage of mobile networks occurs within higher population densities in which networks have to be designed for capacity purposes rather than for wide coverage. Thus, the higher frequency bands are most appropriate for IMT network deployment in dense urban areas.

It can be argued that, in the frequency bands where spectrum availability is limited (e.g. 800 MHz), it would be inefficient to try to allocate both FDD and TDD in the same band due to the amount of

guard band that may be needed between operators. The 3GPP developed the LTE standard over a range of many different bands, each of which is designated by both a frequency and a band number. LTE-TDD and LTE-FDD also operate on different frequency bands, LTE-TDD works better at higher frequencies while LTE-FDD works better at lower frequencies. According to 3GPP LTE frequency bands, the 800 MHz band is used just with FDD scheme whereas the 1 800 MHz band can support both FDD and TDD schemes. Therefore, using 1 800 MHz band can be more advantageous for providing more capacity and interference mitigation in dense urban areas than the 800 MHz band.

A3.2 Approach

Islamic Republic of Iran has initiated a trial project on LTE eMBMS in order to provide TV content via LTE network in part of Tehran capital city of I.R. of Iran. There were two local companies interested in this project and finally one of them has taken charge of a limited trial LTE eMBMS network.

A3.2.1 Frequency bands

There were two candidate frequency bands for this project: 800 MHz and 1 800 MHz bands. Although the 800 MHz band would have been preferred from the coverage perspective, this band is not appropriate for capacity-oriented scenarios such as dense urban areas. Considering the capacity approach, there are two major advantages for the 1 800 MHz band over the 800 MHz band as the follows:

- 1) providing more bandwidth;
- 2) employing TDD schemes.

In addition, most implemented eMBMS projects have been targeted to provide the broadcast and multicast service in high user-density area such as stadiums during entertainment or sport events. Consequently, it is clear that for a dense urban area like Tehran city, the optimal choice is 1 800 MHz and this frequency band has been selected for this trial of LTE eMBMS network.

A3.2.2 Receiver

The user equipment (UEs) must be equipped with eMBMS-enabled chipset in order to receive broadcast and multicast services. The conventional LTE UEs that are currently available on the market do not support eMBMS intrinsically. Therefore, the eMBMS-enabled devices had to be ordered directly from an equipment vendor. This challenge has also been encountered in other LTE eMBMS projects. This is a consequence of the fact that, currently, mobile network operators do not provide commercial services using eMBMS and do not support the required functionality on the UEs. Thus, a limited number of such UE were prepared.

A3.2.3 Deployment

One of the important part of LTE eMBMS network is eMBMS core. The regular LTE core does not basically support eMBMS. The simple and efficient way to cope with this problem is to use remote core. In this method, the content is transferred to a remote core via satellite and reciprocally the content is transmitted to the eNodeB via satellite.

The main intention in the trial was to deliver one regular DVB-T Transport Stream (TS) (with a bit rate of ~22 Mb/s) via eMBMS. The initial test has been done using a single base station operating in the 1 800 MHz frequency band with a channel bandwidth of 15 MHz. The cell size and average throughput are assumed to be around 300 m and 2.5 bit/s/Hz, respectively. As a consequence, the required capacity could be provided to deliver one DVB-T TS (~22 Mb/s) using this eMBMS network. However, with larger cell sizes the achievable throughput would decrease and, as a result, it would not be possible to ensure the required quality or number of broadcast services.

A3.3 Conclusion

The Islamic Republic of Iran has initiated a trial of LTE eMBMS in order to provide broadcast and multicast services via IMT. A local company has conducted this trial project. The 1 800 MHz frequency band has been selected for this project due to its advantages in providing higher capacity than the 800 MHz band. A limited number of eMBMS enabled UEs has been ordered from an equipment vendor. Initial results demonstrate that, the LTE eMBMS in its current version can be appropriate for providing broadcast and multicast services in small geographical areas (e.g. venues for special events) but cannot be a viable solution for a broadcast distribution of TV services on a large scale.

Annex 4

Japan

A national approach to terrestrial IMT in 700 MHz band: Japan approach

A4.1 Introduction

The analogue TV broadcasting had been switched over to the digital TV one in 2012. Currently the highest frequency of the band allocated for digital TV is 710 MHz. The frequency band identified for IMT is 718-748 MHz for up-link and 773-803 MHz for down link in the national frequency allocation. Before the switch-over the band of 770-806 MHz was assigned to a field-pick-up (FPU) for the transmission of the broadcast materials used for the TV broadcasting and a specific radio microphone used in the theatre, broadcasting station and so on. Japan adopted such measures to facilitate the transition of the existing radio services that the operation of FPU systems was moved to (1) the 1 200 MHz band (1 240-1 300 MHz) and (2) 2 300 MHz band (2 330-2 370 MHz), and the operation of the specific radio microphone equipment was moved to (1) the white space band (470-710 MHz), in which the terrestrial digital TV broadcasting is protected from interferences depending on the area, (2) the band dedicated for specific radio microphone (710-714 MHz), and (3) 1.2 GHz band (1 240-1 260 MHz excluding 1 MHz). The frequency bands identified for IMT could be assigned as mentioned above by the measures.

This Annex 4 outlines the measures to facilitate the transition of the existing radio services in the next section.

A4.2 Sharing and coexisting studies for the transition

When considering refarming for the introduction of IMT-2000 in 700 MHz band, the following conditions were taken into account:

- international frequency harmonization, (Targeted IMT band is within the internationally harmonized band identified for IMT);
- to maintain minimum required guard band width with the existing radio services, and (The existing radio services have to be protected);
- to secure IMT band as wide as possible. (Although it might be enough the bandwidth secured would be one required by the planned radio services, it is also true that the targeted IMT band would be as wide as possible, if possible).

On 700 MHz band refarming in Japan, sharing studies, between (1) IMT and IMT, (2) IMT and TV broadcasting, (3) IMT and ITS (Intelligent Transportation System), (4) IMT and FPU, and (5) IMT and radio microphone, were implemented and tried to find out the technical and operational conditions such as guard band between them, required separation distance between each radio station, and engineering work of base station by changing antenna angle pointing and transmitting e.i.r.p. and so on. Anyhow complexity of the studies would be depending on the allocation of the existing radio services and the required bandwidth of IMT in each country.

It was also confirmed that the technical parameters of LTE to be used in the sharing studies in 700 MHz band were covered by ones used in the above mentioned sharing study for IMT-2000 in the 700 MHz band. So the results of the sharing and coexistence study performed for IMT-2000 were adopted in the same manner as the case for LTE in 700 MHz band.

A4.3 Approach

The measures¹⁶ to facilitate the transition of the existing radio systems were introduced to implement the smooth and early reallocation of the frequency bands for the existing radio services, after that the bands can be usable for IMT. In the measures an operator, to whom a new frequency band is assigned, bears expenses required for the existing users to continue their services with use of their new radio systems procured by using the expenses paid by the IMT operators.

The measures were implemented in order to make the harmonized band for IMT as wide as possible within the frequency arrangement of “A5” (703-748 MHz for up-link and 758-803 MHz for down link) of Recommendation ITU-R M.1036.

The operators, who were authorized newly to use the frequency bands after the evaluation of the implementation plan by the Ministry, could negotiate with each existing radio system operators about the schedule of the transition of their existing operation and the expense values required for the transition that were born by all involved IMT operators in accordance with the guidance to implement the construction of IMT base stations in the bands newly assigned by the transition and each IMT operators’ implementation plan authorized by the Ministry.

IMT operators can partially start construction of base stations in the area where the transition of the existing radio stations has finished without waiting for the completion of the whole transition of the existing radio stations in nationwide.

The actual implementation of the measures to facilitate the reallocation of the frequencies is progressed by the general incorporated association that was established jointly by the current three IMT operators, who can, then, facilitate the installation of the IMT base stations. The extent of the progress of the operation by the association is confirmed by the Ministry based on the quarterly report from each IMT operator and the Ministry makes the reports public.

¹⁶ The portal site of the measures, although the description is in Japanese, is <http://www.tele.soumu.go.jp/j/adm/system/ml/mobile/portal/index.htm>

Annex 5

Mexico

National approaches on IMT implementation in the 600 MHz and 700 MHz frequency bands

A5.1 Introduction

As a result of a Decree published in the Official Gazette on 13th June 2013, which amended and supplemented certain provisions of the Constitution of the United Mexican States, the Federal Telecommunication Institute (IFT, by its Spanish acronym) was created as an autonomous public agency, focused on broadcasting and telecommunication. It is responsible for regulating, promoting and supervising the use, development and operation of the radio spectrum, networks and the provision of broadcasting and telecommunication services in Mexico.

Since then, IFT has been focused in building new technical and regulatory strategies regarding frequency band programs derived from the National Radio Spectrum Program referred in the Seventeenth Transitory article, section V of the Decree.

In this context, on December 16th, 2014, IFT Board issued an Agreement¹⁷ which incorporated a “Work Plan to assure optimum use of the 700 MHz and 2.5 GHz bands under universal, non-discriminatory, shared and continuous access principles” and a “Work Plan to rearrange spectrum for broadcasting stations”.

The aim of this Annex is to outline the knowledge that Mexico has obtained from the process of implementing the regulatory provisions, techniques and procedures of spectrum planning within our national approach to implement IMT in the UHF frequency band. The technical and regulatory actions performed in order to successfully achieve the first digital dividend in 698-803 MHz (700 MHz band) will be described, as well as the actions needed in order to foresee the second digital dividend in 614-698 MHz (600 MHz band) in our country.

A5.2 National approaches

614-698 MHz frequency band

The 614-698 MHz frequency band (better known as “600 MHz band”) means for Mexico a great opportunity to implement IMT systems in the near future. Mexico administration accomplished the band identification for IMT by country footnote, with the support by different administrations during last WRC-15.

In March 2018, Mexico started the migration of the remaining 48 over-the-air TV channels in the 614-698 MHz frequency band, to frequency bands below channel 37 (below 608 MHz). Furthermore, in September 2018, Mexico moved one last cable TV channel from the same frequency band below channel 37. With this spectrum planning procedures the 600 MHz band will be ready in the short term for deployment of mobile broadband and to accomplish our second digital dividend.

To fulfil this goal, Mexico is proposing using a reverse FDD configuration for IMT deployment in the 600 MHz band¹⁸. This means downlink frequency of range 617-652 MHz and uplink frequency

¹⁷ It is worth mentioning that this Agreement involves regulatory and technical considerations that are to be carried out by IFT.

¹⁸ For more information over the matter consult Document 5D/162 “Proposal for the revision of Recommendation ITU-R M.1036-5 to include frequency arrangement in the band 470-698 MHz”.

of range 663-698 MHz. One of the reasons of selecting this configuration, is to ensure compatibility with A5 frequency arrangement, which Red Compartida will be using in the 700 MHz band given that both bands will transmit in uplink directions in the adjacent part of the bands (see Fig. 6).

FIGURE 6

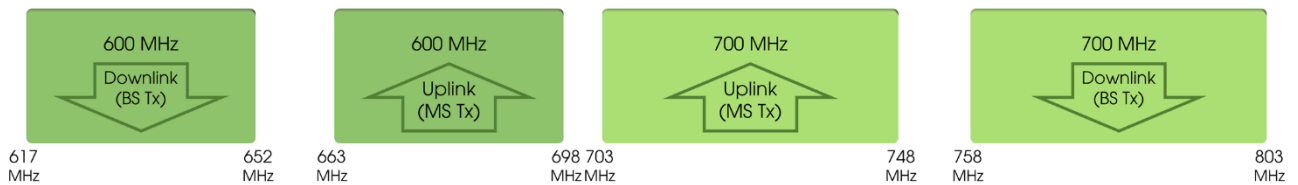

698-803 MHz frequency band

The 698-803 MHz frequency band (better known as “700 MHz band”) implementation, according to the “Work Plan to assure optimum use of the 700 MHz and 2.5 GHz bands under universal, non-discriminatory, shared and continuous access principles”, is bound to promote effective public access to broadband and telecommunication services through a Project known as “Red Compartida”¹⁹, which stands for “Wholesale shared network”. This Project should be understood as a public telecommunications network exclusively destined to sell capacity, infrastructure or wholesale telecommunication services to other concessionaries or resellers.

Red Compartida has 90 MHz available in the 700 MHz band (703-748 MHz uplink and 758-803 MHz downlink) by using the frequency arrangement A5 included in Recommendation ITU-R M.1036-5.

This model is based on a Public-Private Partnership Project that is considered optimal for obtaining state-provided assets, such as spectrum radiofrequencies, but requires a large amount of private investment, which can only be achieved through partnerships in the private sector. It is estimated that it will generate an investment of more than seven billion dollars over the life of the project.

Red Compartida will allow 92.2% of the country's population to have access to some of the best communication technologies available worldwide as it will provide its services through 4G-LTE technology and prepared for 5G evolution.

The first phase of the Red Compartida started operating in March 31, 2018, covering 30% of Mexico's population. After that, the deployment plan will be as follows:

- Third year: Coverage of 50% of the population and 50% of “Pueblos Mágicos”²⁰.
- Fourth year: Coverage of 70% of the population and 75% of “Pueblos Mágicos”.
- Fifth year: Coverage of 85% of the population and all “Pueblos Mágicos”.
- Sixth year: Coverage of 88.6% of the population.
- Seventh year: Coverage of 92.2% of the population.

Thus, the Red Compartida initiative not only leads to one of the largest telecommunications projects in the history of Mexico, but also one of the most spectrum innovative models in the world.

¹⁹ <http://www.sct.gob.mx/red-compartida/index-eng.html>

²⁰ “Magical Villages” The tourism program of Mexico to identify towns, that stand out for their relevance in terms of beauty or historical legacy.

It is important to mention that before implementing IMT in the 700 MHz band, it was necessary to carry out the transition to digital television and the analogue switch-off on all the TV channels allotted in this spectrum portion. For this reason, IFT issued the Work Plan to rearrange spectrum for broadcasting stations, which is intended for an efficient spectrum use and promoting relevant market development of broadcasting.

This Plan considered 470-512 MHz portion to be assigned for broadcasting exclusively, an intensive usage of spectrum portions in the VHF band (54-88 MHz/174-216 MHz) allocated to broadcasting, as well as optimizing TV channels under channel number 37 (608-614 MHz) by means of new advantages originated by new digital television technologies. In addition to that, it is worth mentioning that segment 512-608 MHz is to be used for TV broadcasting services.

Therefore, the Work Plan mentioned above does not only promote and preserve broadcasting services, but also anticipate the scenario for deploying IMT in 600 MHz band and heading the way for planning a second digital dividend in Mexico.

A5.3 Conclusion

Mexico intends to deploy Broadcasting services and IMT applications in separate segments of the UHF bands. As convergence is still on its way, Mexico is opening the path to achieve a balanced distribution between broadcasting services²¹ and IMT implementation in UHF band by performing the actions described throughout this contribution. This also can lead to new frequency arrangements for different IMT bands identified for IMT below 1 GHz such as the 600 MHz Band Plan already proposed in the draft revision version of Recommendation ITU-R M.1036-5.

Annex 6

United States of America Approach on the use of terrestrial IMT systems in frequency bands below 1 GHz identified for IMT

A6.1 Introduction

On March 17 2010, the FCC released The National Broadband Plan²², establishing a roadmap for initiatives to stimulate economic growth, spur job creation and boost America's capabilities in education, health care, homeland security and more. The plan includes sections focusing on economic opportunity, education, health care, energy and the environment, government performance, civic engagement and public safety. The Plan fulfilled a Congressional mandate to ensure every American has “access to broadband capability,” including a detailed strategy for achieving affordability and maximizing use of broadband. One of the key elements of the plan is ensuring efficient allocation and use of government-owned and government-influenced assets. The

²¹ IFT has recently carried out a number of auction processes related to broadcasting services. In the period of 2014-2017 alone, Mexico has assigned two new national television networks, 191 FM broadcasting stations, 66 AM broadcasting stations and 148 regional digital television channels. For more information, see the following link:

<http://www.ift.org.mx/espectro-radioelectrico/licitaciones/radiodifusion>

²² <https://www.fcc.gov/general/national-broadband-plan>

Plan recommended making an additional 500 MHz of spectrum newly available for broadband within 10 years, of which 300 MHz should be available for mobile use within five years. In order to achieve this goal, the FCC established principles to:

- Enable incentives and mechanisms to repurpose spectrum to more flexible uses. Mechanisms include incentive auctions, which allow auction proceeds to be shared in an equitable manner with current licensees as market demands change. These would benefit both spectrum holders and the American public. The public could benefit from additional spectrum for high-demand uses and from new auction revenues. Incumbents, meanwhile, could recognize a portion of the value of enabling new uses of spectrum. For example, this would allow the FCC to share auction proceeds with broadcasters who voluntarily agree to use technology to continue traditional broadcast services with less spectrum.
- Ensure greater transparency of spectrum allocation, assignment and use to foster an efficient secondary market.
- Expand opportunities for innovative spectrum access models by creating new avenues for opportunistic and unlicensed use of spectrum and increasing research into new spectrum technologies.

A6.2 600 MHz

In 2014, the FCC adopted a Report and Order for Incentive Auctions²³. The incentive auction is a new tool²⁴ authorized by Congress to help the Commission meet the Nation’s accelerating spectrum needs. Broadcasters were given the unique financial opportunity in the “reverse auction” phase of the incentive auction to return some or all of their broadcast spectrum usage rights in exchange for incentive payments. By facilitating the voluntary return of spectrum usage rights and reorganizing the broadcast television bands, the FCC could recover a portion of ultra-high frequency (UHF) spectrum for a “forward auction” of new, flexible-use licenses suitable for providing mobile broadband services. Payments to broadcasters that participate in the reverse auction can strengthen broadcasting by funding new content, services, and delivery mechanisms. And by making more spectrum available for mobile broadband use, the incentive auction will benefit consumers by easing congestion on the Nation’s airwaves, expediting the development of new, more robust wireless services and applications, and spurring job creation and economic growth.

The broadcast incentive auction itself comprised of two separate but interdependent auctions – a reverse auction, which will determine the price at which broadcasters will voluntarily relinquish their spectrum usage rights; and a forward auction, which will determine the price companies are willing to pay for flexible use wireless licenses. The lynchpin joining the reverse and the forward auctions is the ‘repacking’ process. Repacking involves reorganizing and assigning channels to the remaining broadcast television stations in order to create contiguous blocks of cleared spectrum suitable for flexible use. In order to be successful, each of the components must work together. Ultimately, the reverse auction requires information about how much bidders are willing to pay for spectrum licenses in the forward auction; and the forward auction requires information regarding what spectrum rights were tendered in the reverse auction, and at what price; and each of these depend on efficiently repacking the remaining broadcasters.

The reverse and forward auctions was integrated in a series of stages. Each stage will consist of a reverse auction and a forward auction. Prior to the first stage, the initial spectrum clearing target is determined. Broadcasters indicate through the pre-auction application process their willingness to

²³ <https://www.fcc.gov/document/fcc-adopts-rules-first-ever-incentive-auction>

²⁴ <https://www.fcc.gov/about-fcc/fcc-initiatives/incentive-auctions/how-it-works>

relinquish spectrum usage rights at the opening prices. Based on broadcasters' collective willingness, the initial spectrum clearing target will be set at the highest level possible (up to 126 megahertz of spectrum) without exceeding a pre-determined national aggregate cap on the interference between wireless providers and TV stations ("impairments") created when TV stations must be assigned to the wireless band. Under this approach, the auction system will establish a band of wireless spectrum that is generally uniform in size across all markets. Then the reverse auction bidding process will be run to determine the total amount of incentive payments to broadcasters required to clear that amount of spectrum.

The forward auction bidding process will follow the reverse auction bidding process. If the "final stage rule" is satisfied, the forward auction bidding will continue until there is no excess demand, and then the incentive auction will close. If the final stage rule is not satisfied, additional stages will be run, with progressively lower spectrum targets in the reverse auction and less spectrum available in the forward auction. The final stage rule is a set of conditions that must be met in order to close the auction at the current clearing target; failure to satisfy the rule would result in running a new phase at the next lowest clearing target.

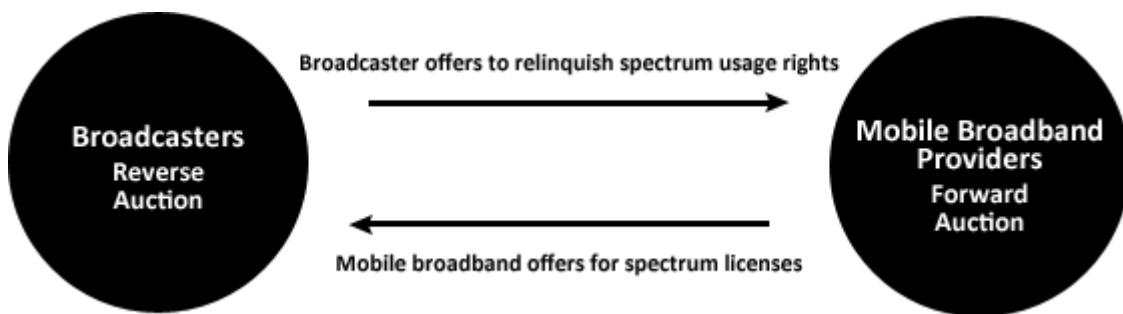

The central objective in designing this incentive auction is to harness the economics of demand for spectrum in order to allow market forces to determine its highest and best use. There is also mindfulness of the other directives that Congress established for the auction, including making all reasonable efforts to preserve, as of the date of the passage of the Spectrum Act, the coverage area and population served of remaining broadcast licensees. The auction affords a unique opportunity for broadcasters who wish to relinquish some or all of their spectrum rights, but it is emphasized that a broadcaster's decision to participate in the reverse auction is wholly voluntary. In the descending clock auction format it was chosen, for example, a broadcaster need only decide whether it is willing to accept one or more prices offered to it as the reverse auction proceeds; if at any point the broadcaster decides a price is too low, it may drop out of the reverse auction. No station will be compensated less than the total price that it indicates it is willing to accept.

The FCC also recognizes the importance of broadcasters that choose not to participate in the reverse auction. To free up a portion of the UHF spectrum band for new, flexible uses, Congress authorized the Commission to reorganize the broadcast television spectrum so that the stations that remain on the air after the incentive auction occupy a smaller portion of the UHF band. The reorganization (or 'repacking') approach adopted will avoid unnecessary disruption to broadcasters and consumers and ensure the continued availability of free, over-the-air television service.

These actions will benefit consumers of telecommunications services. While minimizing disruption to broadcast television service, the United States sought to rearrange the UHF spectrum in order to increase its potential to support the changing needs of 21st Century consumers. The same individuals may be consumers of television, mobile broadband—using both licensed and unlicensed spectrum—and other telecommunications services. To benefit such consumers, and consistent with the framework of the Spectrum Act, the United States has strived for balance in our decision-making process between television and wireless services, and between licensed and unlicensed spectrum uses.

A6.2.1 Band Plan

A “600 MHz Band Plan” was adopted for new services in the reorganized UHF spectrum. By maximizing the spectrum’s value to potential bidders through features such as paired 5 MHz ‘building blocks’, the Band Plan will help to ensure a successful auction. By accommodating variation in the amount of spectrum are recovered in different areas, which depends on broadcaster participation and other factors, the Band Plan will ensure that the repurposing of spectrum for the benefit of most consumers nationwide is not limited by constraints in particular markets. The Band Plan will promote competition and innovation by creating opportunities for multiple license winners and for future as well as current wireless technologies. Because it is composed of a single band of paired spectrum blocks only, our Band Plan also simplifies the forward auction design. For new licensees, flexible-use service rules are adopted, and technical rules similar to those governing the adjacent 700 MHz Band, an approach that should speed deployment in the 600 MHz band. Devices will be required to be interoperable across the entire new 600 MHz band.

The FCC concluded that the 600 MHz Band Plan adopted best supports our central goal of allowing market forces to determine the highest and best use of spectrum, as well as our other policy goals for the incentive auction, including the Commission’s five key policy goals for selecting a band plan. The Band Plan enhances the economic value and utility of the repurposed spectrum by enabling two-way (paired) transmissions throughout this well-propagating ‘coverage band’. This approach also simplifies auction design by offering only a single configuration – paired blocks – which allows for maximum interchangeability of blocks, and enables limited market variation, thus avoiding a “least common denominator” problem. It also provides certainty about the operating environment for forward auction bidders by establishing guard bands between television and wireless services in order to create spectrum blocks that are reasonably designed to protect against harmful interference²⁵. Further, the 600 MHz Band Plan promotes competition. By offering only paired blocks in a single band, and by licensing on a Partial Economic Area (PEA) basis, the 600 MHz Band Plan will promote participation by both larger and smaller wireless providers, including rural providers, and encourage new entrants. Finally, the 600 MHz Band Plan, composed of a single, paired band, promotes interoperability and international harmonization.

The 600 MHz Band Plan adopted consists of paired uplink and downlink bands offered in 5 + 5 megahertz blocks. The uplink band will begin at channel 51 (698 MHz), followed by a duplex gap, and then the downlink band. The 600 MHz Band will be licensed on a geographic area license basis, using PEAs. Further, market variation will be accommodated: specifically, the 600 MHz Band Plan will be used in all areas where sufficient spectrum is available; and in constrained markets where less spectrum is available, fewer blocks, or impaired blocks, than what is offered generally in the 600 MHz Band Plan may be offered. Finally, technically reasonable guard bands are established to prevent harmful interference and to ensure that the spectrum blocks are as interchangeable as possible.

Because the FCC did not know the exact number of blocks licensed or their frequencies until the incentive auction concludes, the 600 MHz Band Plan adopted represents a framework for how to license the repurposed spectrum. The Technical Appendix sets forth each of the specific 600 MHz Band Plan scenarios based on the number of television channels cleared; ultimately, the repurposed spectrum will be licensed according to one of these scenarios.

²⁵ Variation in the amount of spectrum recovered in different areas requires protection of both services using an inter-service interference prediction methodology.

See: https://apps.fcc.gov/edocs_public/attachmatch/FCC-15-141A1.pdf

Ultimately, the uniform Band Plan adopted did not require inter-service sharing.

Below are shown two examples of the 600 MHz Band Plan scenarios set forth in the Technical Appendix of the Report and Order.

FIGURE 7

84 MHz scenario

21	22	23	24	25	26	27	28	29	30	31	32	33	34	35	36	37	3	A	B	C	D	E	F	G	11	A	B	C	D	E	F	G	700 MHz UL
----	----	----	----	----	----	----	----	----	----	----	----	----	----	----	----	----	---	---	---	---	---	---	---	---	----	---	---	---	---	---	---	---	------------

FIGURE 8

126 MHz scenario

21	22	23	24	25	26	27	28	29	9	A	B	C	D	E	F	3	37	3	G	H	I	J	11	A	B	C	D	E	F	G	H	I	J	700 MHz UL
----	----	----	----	----	----	----	----	----	---	---	---	---	---	---	---	---	----	---	---	---	---	---	----	---	---	---	---	---	---	---	---	---	---	------------

In the first example, 84 MHz of television spectrum is repurposed. A total of seven 5 + 5 MHz paired blocks are licensed for new, flexible use. An 11-MHz guard band or ‘duplex gap’ protects against harmful interference between 600 MHz uplink and downlink services, and a 3 MHz guard band protects against harmful interference between 600 MHz downlink services and channel 37. Channel 37 itself, along with the 3 MHz guard band, serves as a guard band between 600 MHz downlink services and television services, which occupy the UHF spectrum down from channel 36 down. In the second example, 126 MHz of television spectrum is repurposed. Ten 5 + 5 MHz paired blocks are licensed for new, flexible use. The duplex gap is 11 MHz, there are 3-MHz guard bands on either side of channel 37, and a 9-MHz guard band between 600 MHz downlink services and television services, which occupy the UHF spectrum from channel 29 down.

The FCC noted that offering downlink-only blocks in the 600 MHz auction may undermine competition. Because providers must pair downlink-only blocks with existing spectrum holdings, new entrants would not be able to use downlink-only blocks, thus limiting their utility. In contrast, offering paired spectrum blocks will benefit all potential 600 MHz Band licensees. Further, offering downlink-only blocks would further complicate the auction design without a commensurate benefit. As explained above, downlink-only blocks are less valuable than paired blocks to bidders, and offering both paired and unpaired blocks would introduce additional differences among licenses in the forward auction and increase the amount of time the auction takes to close.

Finally, our all-paired Band Plan generally has nationally consistent blocks and guard bands, which will promote interoperability. In contrast, offering downlink-only blocks could exacerbate interoperability concerns by separating the 600 MHz Band into two bands. If both unpaired and paired blocks are licensed, it would be expected that the industry standards body would create separate bands for the paired blocks and unpaired blocks, as it has done previously. If the 600 MHz Band were split into two separate bands, then some devices could support part, but not all, of the Band. Concerns were also raised over the potential for wireless carriers using downlink-only blocks to configure their networks so as to create barriers to roaming. Limiting the auction to paired blocks will help to ameliorate these concerns. It will also promote international harmonization, and in particular, should help to address cross-border issues with Canada and Mexico.

A6.2.2 Repurposing for mobile use

On 18 January 2017, the auction satisfied both of the conditions of the final stage rule, assuring that the auction will close in Stage 4. At \$19.8 billion in gross revenue for 70 MHz of spectrum, the incentive auction is among the highest grossing auctions ever conducted by the FCC. The auction created a first-of-its-kind market for repurposing commercially-held spectrum licenses for new uses. The model is part of the foundation of the future of U.S. spectrum allocation and use policy designed for 21st century realities. The US incentive auctions started in March 2016 and has satisfied the rules for the final stage which means that 84 MHz (614-698 MHz) will be cleared from broadcasting including 70 MHz of licensed spectrum and 14 MHz for unlicensed. The Band Plan established is the following:

FIGURE 9

Frequency arrangement from US incentive auction

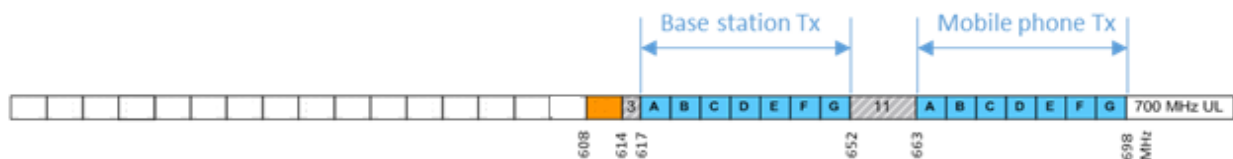

Following the conclusion of the incentive auction, the transition to the reorganized UHF band will be as rapid as possible without causing unnecessary disruption. Television stations that voluntarily turn in their licenses or agree to channel share must transition from their pre-auction channels within three months of receiving their reverse auction payments. The time required for stations reassigned to a new channel to modify their facilities will vary, so their construction deadlines will be tailored to their situations. This approach will ensure that stations transition as quickly as their circumstances allow, and allow coordination of deadlines where, for example, one station must vacate a channel before another can begin operating on its new channel. No station will be allowed to operate on a channel that has been reassigned or repurposed more than 39 months after the repacking process becomes effective. In other words, the repurposed spectrum will be cleared no later than 39 months after the effective date. Most new licensees should have access to 600 MHz spectrum well before then. Consistent with Congress's mandate, procedures are also established to reimburse costs reasonably incurred by stations that are reassigned to new channels, as well as by multichannel video programming distributors to continue to carry such stations.

As Congress recognized, the incentive auction and the transition that follows require coordination with our cross-border neighbours, Canada and Mexico. Because of these common borders, the Commission has established processes and agreements to protect television and wireless operations in border areas from harmful interference. The FCC staff has used these processes to fully inform Canadian and Mexican officials regarding the incentive auction and, beginning in 2013, formed technical groups to meet routinely to plan for harmonious use of the reorganized UHF band following the incentive auction. Commission leadership has supplemented these efforts, meeting with their Canadian and Mexican counterparts to emphasize the need for and mutual benefits of harmonization.

A6.3 700 MHz

The recovery of the 700 MHz Band was made possible by the conversion of television broadcasting from the existing analogue transmission system to a digital transmission system. Because the digital television (DTV) transmission system is more spectrally efficient than the analogue system, less spectrum will be needed for broadcast television service after the transition to DTV on channels 2 to

51 is complete. The USA which switched-off its analogue transmissions in 2009, and was the first Administration to relocate the channels 52 to 69 to advanced wireless service.

FIGURE 10
TV allocation in the United States of America

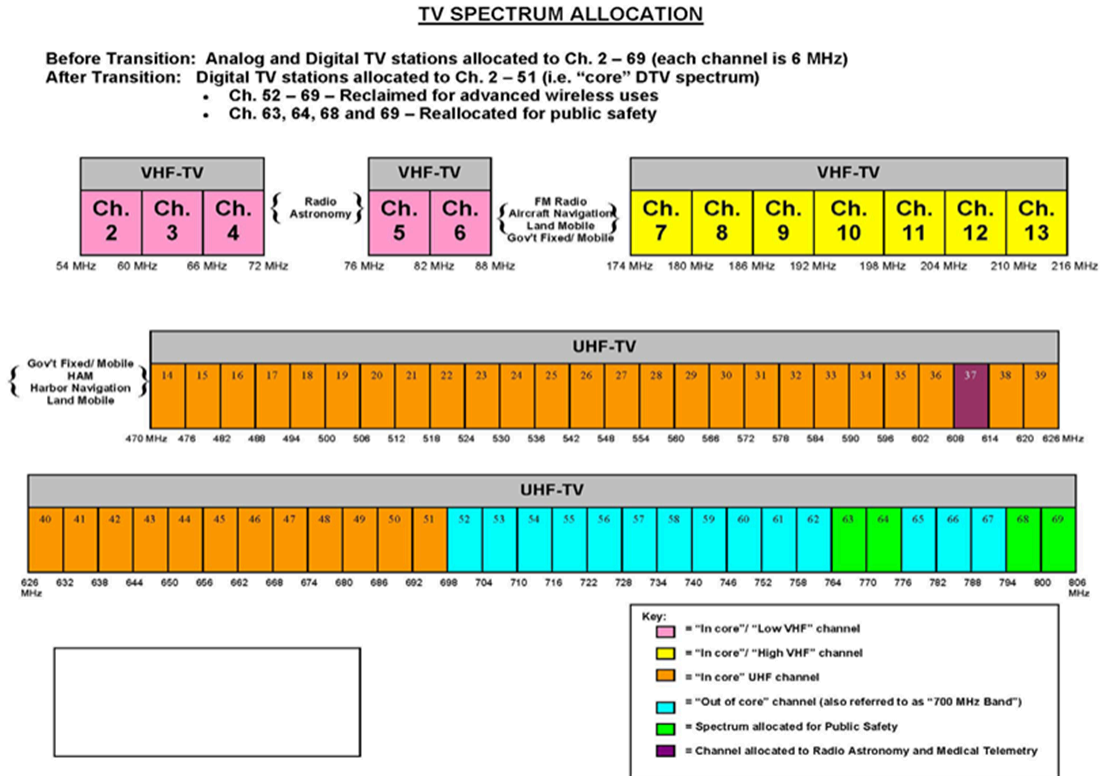

The successful auction of the 700 MHz band has facilitated a nationwide roll-out of IMT (LTE) deployments, including establishing valuable spectrum for public safety uses. The U.S. 700 MHz Band Plan divides the 698-806 MHz frequency range into a lower 700 MHz portion and an upper 700 MHz portion. The final Band Plan is available here:

<http://wireless.fcc.gov/auctions/data/bandplans/700MHzBandPlan.pdf>

To enable operability along border areas, the FCC has worked through bilateral coordination processes with its neighbours to address issues with variation in adopted band plans. The U.S. and APT FDD band plans are incompatible in their assignment of uplink and downlink spectrum therefore careful coordination of spectrum is required along the border areas. Due to overlapping base and mobile transmission of one band plan with base and mobile receiving frequencies of the other band plan, several interference scenarios can be found along the border.

According to a July 2012 survey, the U.S. 700 MHz ecosystem has grown rapidly to include 193 LTE device products including Modules for M2M, notebooks, phones, routers for hotspots, tablets and USB modems supported by over 18 manufacturers. 3GPP defines a number of bands in 700 MHz: Band 12: (Lower 700 MHz) 699-716 MHz/729-746 MHz; Band 13: (Upper C 700 MHz) 777-787 MHz/746-756 MHz; Band 14: (Upper D 700 MHz) 788-798 MHz/758-768 MHz; Band 17: (Lower B, C 700 MHz) 704 -716 MHz/734-746 MHz.

Annex 7

United States of America Approach on the planning and implementation of terrestrial IMT systems in the frequency band 3 550-3 700 MHz

A7.1 Introduction

On 17th April 2015, the FCC released rules²⁶ for the Citizen’s Broadband Radio Service (CBRS) for commercial use of 150 megahertz in the 3 550-3 700 MHz band (3.5 GHz band). Advances in radio and computing technologies provide new tools to facilitate more intensive spectrum sharing. The new rules use these tools to dissolve some age-old regulatory divisions, between commercial and federal users, exclusive and non-exclusive authorizations, and private and carrier networks. Starting from some of the recommendations of the President’s Council of Advisors on Science and Technology (PCAST), these rules incorporate a wide range of viewpoints and information collected through three rounds of notice and comment.

The United States federal/non-federal sharing arrangement in this band is part of a broader three-tiered sharing framework enabled by a Spectrum Access System (SAS). Incumbent users represent the highest tier in this framework and receive interference protection from Citizens Broadband Radio Service users. Protected incumbents include the federal operations, as well as Fixed Satellite Service (FSS) and, for a finite period, grandfathered terrestrial wireless operations in the 3 650-3 700 MHz portion of the band. The Citizens Broadband Radio Service itself consists of two tiers – Priority Access and General Authorized Access (GAA) – both authorized in any given location and frequency by a SAS. As the name suggests, Priority Access operations receive protection from GAA operations. Priority Access Licenses (PALs), defined as an authorization to use a 10 megahertz channel in a single census tract for three years, will be assigned in up to 70 megahertz of the 3 550-3 650 MHz portion of the band. GAA use will be allowed, by rule, throughout the 150 MHz band. GAA users will receive no interference protection from other Citizens Broadband Radio Service users.

The new rules advance a potential solution to a long-standing problem in spectrum policy: how to select the most appropriate commercial authorization or licensing mechanism for a new band. The record has brought us back to first principles. The FCCe considered ideas from three major traditions in spectrum management: flexible-use geographic licensing, site-based frequency coordination, and unlicensed authorization. Ultimately, the United States adopted a hybrid framework that selects, automatically, the best approach based on local supply and demand. Where competitive rivalry for spectrum access is low, the GAA tier provides a low-cost entry point to the band, similar to unlicensed access. Where rivalry is high, an auction resolves mutually exclusive applications in specific geographic areas for PALs. Finite-term licensing facilitates evolution of the band and an ever-changing mix of GAA and Priority Access bandwidth over time. The SAS serves as an advanced, highly automated frequency coordinator across the band. It protects higher tier users from those beneath and optimizes frequency use to allow maximum capacity and coexistence for both GAA and Priority Access users.

This regulatory adaptability should make the 3.5 GHz Band hospitable to a wide variety of users, deployment models, and business cases, including some solutions to market needs not adequately served by our conventional licensed or unlicensed rules. Carriers can avail themselves of “success-based” license acquisition, deploying small cells on a GAA basis where they need additional capacity and paying for the surety of license protection only in targeted locations where

²⁶ <https://www.fcc.gov/document/fcc-releases-rules-innovative-spectrum-sharing-35-ghz-band>

they find a demonstrable need for more interference protection. Real estate owners can deploy neutral host systems in high-traffic venues, allowing for cost-effective network sharing among multiple wireless providers and their customers. Manufacturers, utilities, and other large industries can construct private wireless broadband networks to automate processes that require some measure of interference protection and yet are not appropriately outsourced to a commercial cellular network. Smart grid, rural broadband, small cell backhaul, and other point-to-multipoint networks can potentially access three times more bandwidth than was available under our previous 3 650-3 700 MHz band rules. All of these applications could share common wireless technologies, providing economies of scale and facilitating intensive use of the spectrum.

In specifying rules for the SAS – the lynchpin of the Citizens Broadband Radio Service – the FCC balance a need for clear definition of its role, purposes, and functions against a desire to allow market forces and industry standards to inform the specifics of implementation. The FCC opened a process by which multiple entities can apply for certification to operate as SAS Administrators. Through this approval process, applicants will demonstrate their ability to perform the enumerated SAS functions. Because the regime depends on a high degree of interaction among different users, the approval process will be designed to confirm the ability of a SAS to ensure that lower tiers do not transgress the rights of higher tiers. This will be especially important with respect to incumbent federal users of the band.

A7.2 Access Model and Band Plan

Three-Tier Access Model

Under this framework, existing primary operations – including authorized federal users and grandfathered FSS earth stations – would make up the Incumbent Access tier and would receive protection from harmful interference consistent with the proposed rules. The Citizens Broadband Radio Service would be divided into Priority Access and GAA tiers of service, each of which would be required to operate on a non-interference basis with the Incumbent Access tier. GAA users would also be required to operate on a non-interference basis with respect to Priority Access Licensees. The FCC also proposed that any party that meets basic eligibility requirements be eligible to hold a PAL or, when authorized, operate a CBSD on a GAA basis in the Citizens Broadband Radio Service. In addition, the FCC proposed to apply the three-tier authorization model across the entire 3.5 GHz Band.

An example Band Plan is shown in Fig. 11.

FIGURE 11

Potential Band Plan

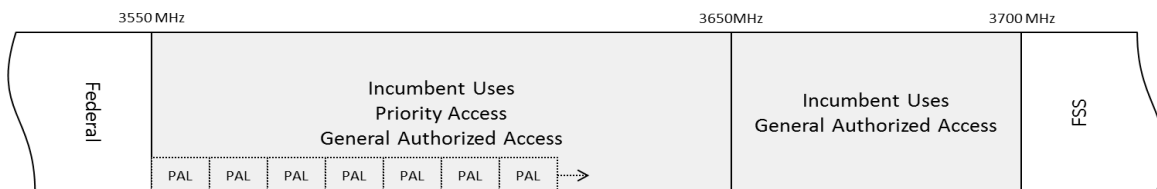

The FCC decided that a maximum of 70 MHz may be reserved for PALs in any given license area at any time and the remainder of the available frequencies should be made available for GAA use. This approach will benefit Priority Access Licensees and GAA users alike. Priority Access Licensees will have more predictable access to spectrum. GAA users will potentially have access to all 150 MHz in the band in areas where there are no PALs issued or in use and up to 80 MHz where all PALs are in use. Note, however, that both PAL and GAA spectrum access will necessarily be constrained by the need to protect Incumbent Users throughout the band. In addition, the FCC

found that permitting opportunistic access to unused Priority Access channels would maximize the flexibility and utility of the 3.5 GHz Band for the widest range of potential users. Allowing GAA users to access bandwidth that is not used by Priority Access Licensees can ensure that the band will be in consistent and productive use.

After review of the record, the FCC adopted emissions and interference limits that will further the Commission’s goals and promote effective coexistence of different users in the band. Specifically, the FCC adopted the following:

- -13 dBm/MHz from 0 to 10 MHz from the SAS assigned channel edge;
- -25 dBm/MHz beyond 10 MHz from the SAS assigned channel edge down to 3 530 MHz and up to 3 720 MHz;
- -40 dBm/MHz below 3 530 MHz and above 3 720 MHz.

FIGURE 12

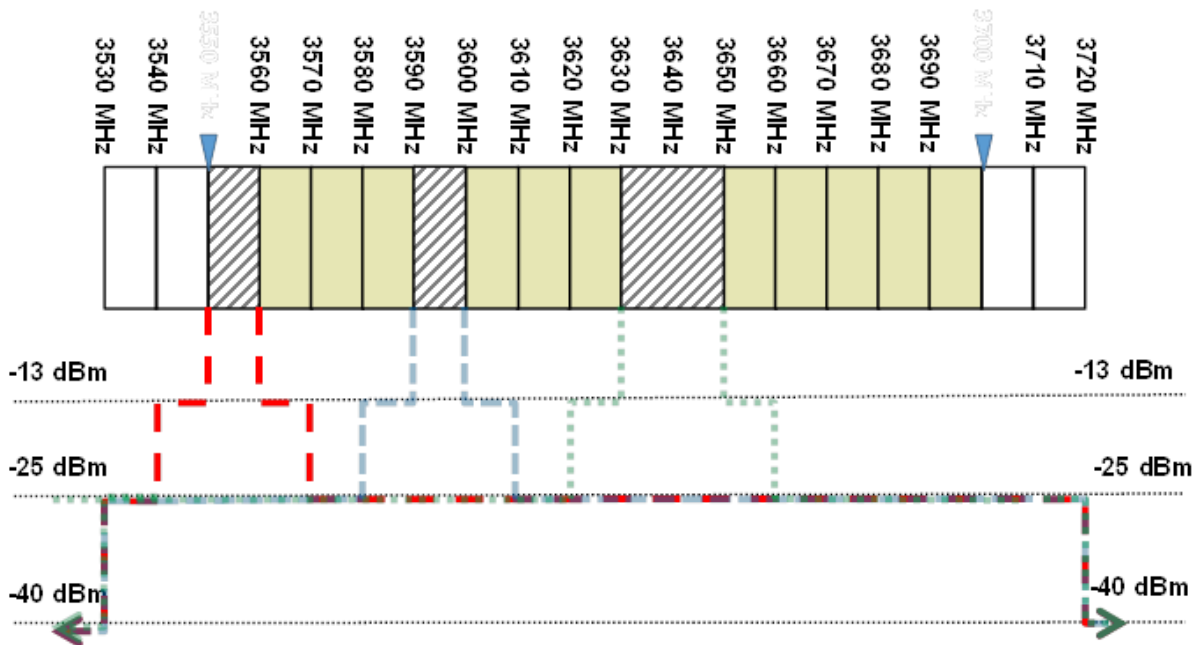

The Table below summarizes the main technical and operational characteristics of Category A and Category B Citizen Broadband Service Devices.

CBSD Category	Maximum e.i.r.p. (dBm/10 MHz)	Maximum PSD (dBm/MHz)	CBSD installations
Category A	30	20	<ul style="list-style-type: none"> - Indoor - Outdoor max 6 m HAAT
Category B	47	37	<ul style="list-style-type: none"> - Outdoor only - Professional installation

A7.3 Operations near international borders

The FCC adopted rules and commits to working with Canadian and Mexican authorities to determine how best to coordinate in-band and adjacent band frequency use in the 3.5 GHz band near international borders. This approach is consistent with our usual practice for new services. SAS Administrators will be required to demonstrate that their systems can and will enforce agreements

between the U.S., Canadian, and Mexican governments regarding commercial operations in the 3.5 GHz band. The specific methods of enforcement will be determined and implemented by SAS administrators, with appropriate Commission oversight, after the agreements are in place.

In addition, Industry Canada recently completed a consultation on the 3 475-3 650 MHz band which will allow the introduction of mobile services in the band²⁷. We will work with Canadian officials to ensure effective cross-border coordination of new devices or services introduced in the band.

A7.4 Spectrum Access System

FIGURE 13

Illustrative end-to-end citizens broadband radio service architecture

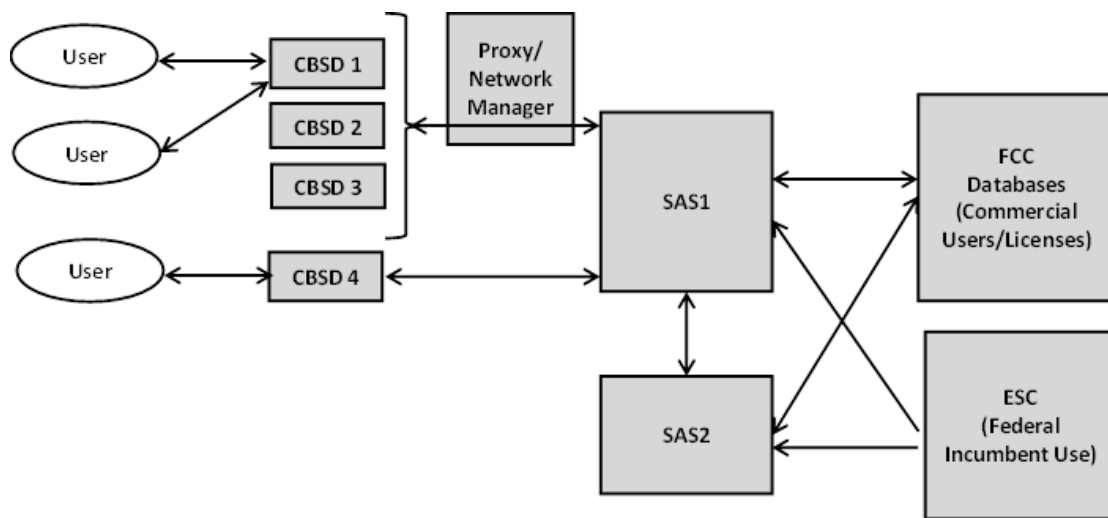

High level SAS requirements

The SAS should perform the high-level functions listed below as well as certain additional functions needed to address changes to the rules governing CBSDs and Incumbent Users. The core functions that a SAS must perform are as follows:

- Determine the available frequencies at a given geographic location and assign them to CBSDs.
- Determine the maximum permissible transmission power level for CBSDs at a given location and communicate that information to the CBSDs.
- Register and authenticate the identification information and location of CBSDs.
- Enforce Exclusion and Protection Zones, including any future changes to such Zones, to ensure compatibility between Citizens Broadband Radio Service users and incumbent federal operations.
- Communicate with the ESC and ensure that CBSDs operate in a manner that does not interfere with federal users.
- Ensure that CBSDs protect non-federal incumbent users consistent with the rules.

²⁷ See Industrie Canada, Decisions Regarding Policy Changes in the 3 500 MHz band (3 475-3 650 MHz) and a New Licensing Process, DGSO-007-14 (2014), available at: <http://www.ic.gc.ca/eic/site/smt-gst.nsf/eng/sf10914.html>

- Protect Priority Access Licensees from impermissible interference from other Citizens Broadband Radio Service users.
- Facilitate coordination between GAA users to promote a stable spectral environment.
- Ensure secure and reliable transmission of information between the SAS, ESC, and CBSDs.
- Protect Grandfathered Wireless Broadband Licensees until the end of the grandfather period.
- Facilitate coordination and information exchange between SASs.

In December 2016, the FCC conditionally approve seven entities as Spectrum Access System (SAS) Administrators in the 3 550-3 700 MHz band (3.5 GHz band). The SAS will coordinate three tiers of users in the 3.5 GHz band, making the band available for commercial use on a shared basis with existing federal and non-federal incumbents. Through their proposals, these seven entities each sufficiently demonstrate the technical and financial capability, as required by the SAS/ESC Proposal Public Notice, to move on to the next phase of the approval process prior to final approval.

Annex 8

Tunisia

A national approach on IMT deployment in the 700 MHz frequency band

A8.1 Introduction

As part of the implementation of the national strategy for the development of very high-speed networks in Tunisia, the National Agency of Frequencies (ANF) has launched a public consultation on “700 MHz band allocation modalities, Perspectives and Challenges”.

The main lines of which have been drawn up with the “Tunisie Digitale 2020” project and in particular the development of infrastructure in terms of spectrum of radio frequencies for the deployment of mobile wide mobile broadband networks, the National Frequencies Agency is seeking, through this public consultation, to obtain the opinions of the various parties concerned on the various possible modalities for the allocation of the 700 MHz band in terms of quantity, method and service benefit (public mobile operator, PMR, or other...).

The ANF wishes to define the next steps which will allow mobile networks with very high speed to continue their development in Tunisia.

To contribute to the continuous modernization of mobile networks, ANF has two methods:

- The reuse of the frequency bands already allocated with new and more efficient technologies.
- The allocation of new frequency bands.

A8.2 Tunisian approach

A8.2.1 700 MHz band

In Tunisia the 700 MHz band has been used for analogue television. A reassignment of this band for IMTs entered into force in November 2015 in Region 1, and from December 2016 in Tunisia

following the transition to DTT. The technical conditions for the use of this frequency band and the channel arrangements were determined in 2015.

The 700 MHz and 800 MHz frequency bands have been the subject of crucial discussions since 2007 in order to achieve global harmonization. Region 1 began with the allocation of the 800 MHz band to IMTs, the 700 MHz band will perfect this global harmonization of the spectrum for very high mobile broadband.

Public safety users are an important community both economically and socially but the market for systems based on public safety standards is much smaller than for commercial cellular. Specialised public safety and critical communications technology cannot attract the level of investment and global R&D that goes into commercial cellular networks. Establishing common technical standards for commercial cellular and public safety offers advantages to both communities:

- the public safety community gets access to the economic and technical advantages generated by the scale of commercial cellular networks; and
- the commercial cellular community gets the opportunity to address parts of the public safety market as well as gaining enhancements to their systems that have interesting applications to consumers and businesses.

A8.2.2 Consideration

Taking into account that:

- the frequency band 694-790 MHz is also allocated in Region 1 to the broadcasting service on a primary basis and that the GE-06 agreement applies before this and the bands above and below;
- coexistence with the 800 MHz Band Plan (using a reversed duplex arrangement) is achieved by placing the 700 MHz downlink band (using a conventional duplex arrangement) adjacent to the 800 MHz downlink band;
- as an alternative to the optional unpaired frequency arrangement (SDL) administrations could choose other options such as Programme Making and Special Events (PMSE), Public Protection and Disaster Relief (PPDR), Machine to Machine (M2M) that could respond to additional demands by using all or part of the duplex gap of the paired Band Plan (733-758 MHz) and, if appropriate, the guard bands;
- the protection of the broadcasting service below 694 MHz from MFCN (Mobile/Fixed Communications Networks) implies a guard band of 9 MHz above 694 MHz;
- for the protection of the broadcasting service below 694 MHz additional measures may need to be applied by administrations at the national level to manage possible interference as a result of nearby MFCN base stations, taking into account the experience of the 800 MHz band.

A8.2.3 Approach

The National Agency of Frequencies (ANF) conducted a public consultation, between June and August 2017, in order to obtain the views of concerned parties on possible modalities for the allocation of the 700 MHz band in terms of quantity, method and service.

The analysis of the amount of spectrum already allocated to IMTs in Tunisia consider several elements; population density, the evolution of the traffic and the geographical extent of the area at which the frequencies are used.

Regarding the evolution of mobile networks in Tunisia, the concerned actors believe that the main developments in the coming years are the 4.5G and 5G while taking into account the establishment of PPDR networks.

In Tunisia, the decision about the amount of spectrum to be allocated to each operator takes in account the state of competition in the mobile telecommunications market and the degree of maturity in the market. From a technical point of view, and in order to exploit the best performance of the mobile technology to be deployed, a minimum of 10 MHz could be enough with the availability of carrier aggregation technique with other bands.

Many actors recommend assigning contiguous 2×10 MHz in 700 MHz band to each operator. They consider that smaller amounts of spectrum (e.g. 2×5 MHz) increase deployment costs and prevent operators from providing true mobile broadband services.

To meet the needs of the PPDR spectrum, especially at the edge of coverage, some actors suggests that a minimum of 2×10 MHz of contiguous spectrum block from 2×30 MHz to be reserved for broadband PPDR applications.

According to the mentioned concern, Tunisia allocated 2×10 MHz for PS-LTE in the frequency band (723-733) MHz on UL and (778-788) MHz on DL.

Annex 9

India: National approach on IMT deployment

A9.1 Introduction

In India, spectrum allocations at present are technology neutral. The spectrum bands or parts thereof for IMT services namely 700 MHz; 800 MHz; 900 MHz, 1 800 MHz; 2 100 MHz; 2 300 MHz, 2 500-2 690 MHz, 3 300-3 400 MHz and 3 400-3 600 MHz are available for telecom services in India.

A9.2 Approach

Cellular telephony was opened up in 1992 with a Duopoly regime, GSM as the mandated technology (900 MHz band), Receiving Party Pays (RPP) system and with a 10-year license. The entire country was divided into 22 licensed service areas. The Metro Licenses were awarded in 1994 based on prescribed criteria and Circle Licenses were awarded in 1995 through single stage bidding process. A cumulative maximum spectrum up to 4.4 MHz in the bands 890-902.5 MHz and 935-947.5 MHz (GSM 900 MHz band) was permitted initially. The objectives of the National Telecom Policy of 1999 prescribed:

- the access to telecommunications shall be put to utmost importance for achievement of the country's social and economic goals;
- the availability of affordable and effective communications for the citizens to be at the core of the vision and goal;
- creation of modern and efficient telecommunications infrastructure taking into account the convergence of IT, media, telecom and consumer electronics;
- and transform in a time bound manner, the telecommunications sector to a greater competitive environment in both urban and rural areas by providing equal opportunities and level playing field for all players.

During that period there were separate licenses for Cellular, Basic (Wireline etc.), National Long Distance, International Long Distance, Paging and Satellite Services etc. In 2003 the Basic and Cellular licenses were merged into a Unified Access Service License.

Between 2004 and 2008, over 200 licenses were awarded for 22 different Licensed Service Areas, to provide commercial telecom services. As a result, each Licensed Service Area had approximately ten telecom service providers.

A9.3 Enhancing spectrum availability for IMT systems in India

Since 2010, spectrum auctions have been regularly held for offering spectrum in a transparent manner through market related process. In the year 2010, spectrum in 2 100 MHz band (for 3G services) and 2 300 MHz band (for BWA services) were put to auction in 22 Licensed Service areas. Thereafter, spectrum auction for providing commercial telecom services have been held at least once each year during 2012-2016. During this period, the spectrum in bands 700 MHz; 800 MHz, 900 MHz, 1 800 MHz, 2 100 MHz, 2 300 MHz and 2500 MHz bands had been put to auction. The 700 MHz spectrum band, put for auction in 2016, was not acquired during auction by the service providers in any of the Licensed Service Area. In August, 2018, the regulator²⁸ made recommendations for further auction of 700 MHz; 800 MHz; 900 MHz, 1 800 MHz; 2 100 MHz; 2 300 MHz, 2 500 MHz, 3 300 MHz and 3 400 MHz bands .

²⁸ <http://main.trai.gov.in/sites/default/files/RecommendationsAuctionofSpectrum01082018.pdf>

A9.4 National Telecom Policy (NTP), 2012

The preamble of NTP, 2012 provides the continued predominant role of wireless technologies in delivery of services in ICT sector. NTP-2012 incorporates framework for increasing the availability of spectrum for telecom services including triple play services (voice, video and data) for which broadband is the key driver. This policy directive is to move towards Unified Licence regime in order to exploit the attendant benefits of convergence, spectrum liberalisation and facilitate delinking of the licensing of Networks from the delivery of Services to the end users in order to enable operators to optimally and efficiently utilise their networks and spectrum by sharing active and passive infrastructure. The objective has been to enhance the quality of service, optimize investments and help address the issue of the digital divide. Further, the policy endeavoured to make the spectrum available at a price determined through market related processes.

The policy directive of liberalisation of spectrum to enable use of spectrum in any band to provide any service in any technology as well as spectrum, sharing and, trading was successfully implemented by the Government. As prescribed by this policy, India has migrated to the Unified Licensing (UL) regime in which there is a single license for all telecommunication services.

A9.5 National Digital Communications Policy (NDCP), 2018²⁹

National Digital Communications Policy (NDCP), 2018³⁰. This Policy recognizes, among other things, Spectrum as a key natural resource for public benefit to achieve India's socio-economic goals, ensure transparency in allocation and optimise availability and utilisation by:

- i) Identifying and making available new Spectrum bands for Access and Backhaul segments for timely deployment and growth of 5G networks.
- ii) Making available harmonized and contiguous spectrum required for deployment of next generation access technologies.
- iii) Further liberalizing the spectrum sharing, leasing and trading regime.
- iv) Enabling Light Touch licensing/ de-licensing of spectrum for broadband proliferation.
- v) Promoting the co-use/ secondary use of spectrum.

A9.6 Making bands contiguous

Until 2015, all access spectrum had to be purchased in the primary market through auctions. The Government subsequently initiated an administrative process for spectrum harmonization to rearrange spectrum in order to make it contiguous. This has greatly helped the licensees (service providers) in offering better Mobile Broadband services.

The Spectrum which was predominantly being used for 2G was harmonised. The harmonization activity was completed pan-India for 1 800 MHz. This spectrum is spatially and geographically contiguous making it more suitable for mobile broadband services. The completion of harmonization activity enabled the country's efforts for deployment of more efficient networks and affordable mobile broadband services.

Harmonisation of other spectrum bands 2 300 MHz, 2 100 MHz and 900 MHz has also been completed in 2018. This effort has enabled better broadband services to be provided.

²⁹ <http://dot.gov.in/whatsnew/national-digital-communications-policy-2018>

³⁰ <http://dot.gov.in/whatsnew/national-digital-communications-policy-2018>

A9.7 Subscriber base

The country witnessed exponential growth in subscriber base (wireless + wireline) since the onset of 3G and LTE services from 2010. The rate of Subscriber growth in India in the period of 2010 to March 2019 is as shown by Fig. 14.

FIGURE 14
Subscriber base in India

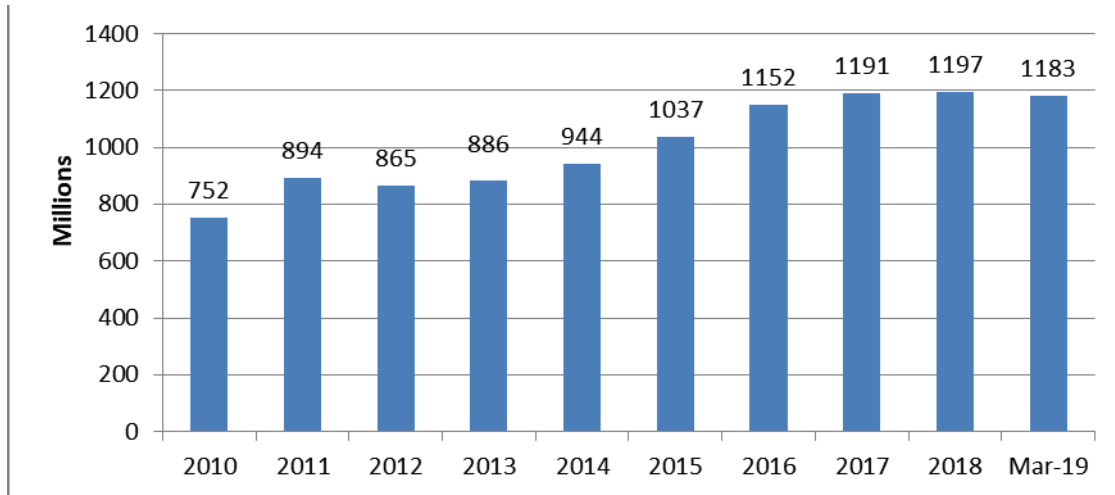

A9.8 Network deployments and accessibility

The deployment pattern in the India approach indicates that there is a considerable investment and deployment in 4G as is evident in the number of base stations deployed in the period depicted below which indicates the percentage wise growth since July 2016. This demonstrates that there is high demand for Mobile Broadband and the need to cater for the increasing appetite for data services in India. Details of growth in base stations is given in Fig. 15.

FIGURE 15

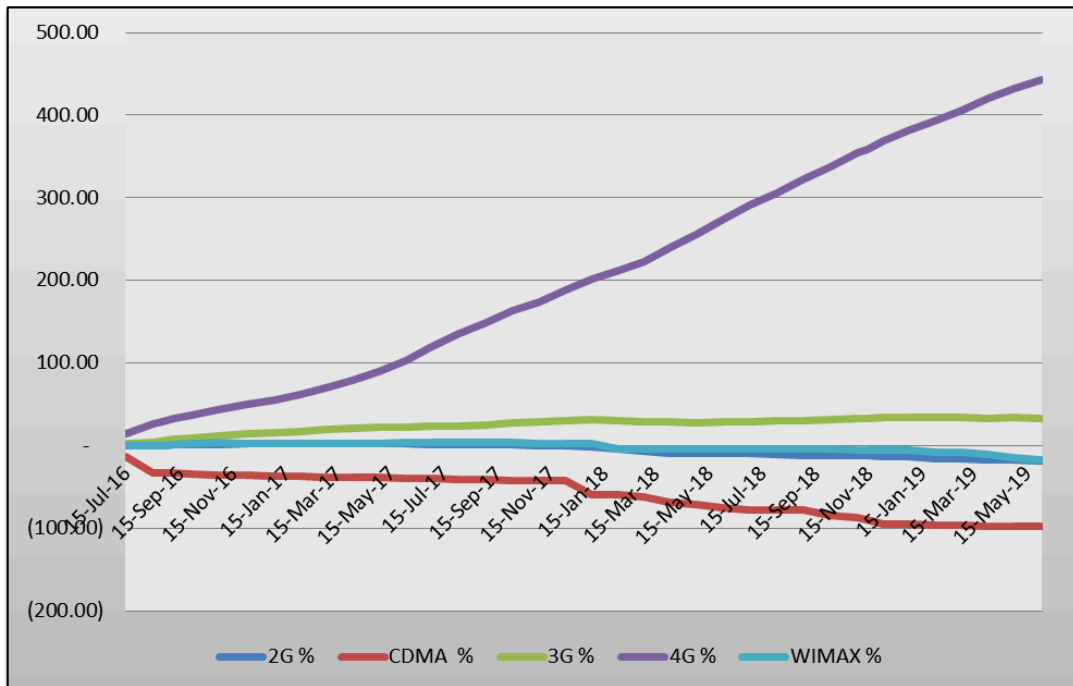

Annex 10

France: National field report on the introduction of IMT in the 800 and 700 MHz bands

A10.1 Introduction

The 800 MHz band has been allocated to Mobile Service in the late 2011 and was previously used by Digital Terrestrial Television (DTT) services. Mobile Networks Operators (MNOs) started using the band in 2012. Compatibility studies with adjacent band below 800 MHz were necessary to establish the technical conditions that minimize interference between LTE 800 networks and DTT services below 790 MHz. Mitigation techniques were added in order to handle the residual interference cases.

In 18th June 2015, based on the national decision taken at the end of 2014, the refarming of the 700 MHz band previously used by DTT, has started to Mobile Services since April 2016, 5th, until mid-2019. To enable this refarming and proceed the evolution of DTT platform, two national DTT multiplexes were shut-down and the entire DTT platform had to switch to the most efficient MPEG-4 coding standard (in terms of spectrum efficiency). The new usage of this standard allows at least the 31 national channels to be broadcasted within only 6 multiplexes with High Definition (HD) for most channels in mainland France.

The law No° 2015-1267 from October 2015³¹ settled that the 470-694 MHz band remains available for DTT at least until 2030. This decision is compliant with a report conducted at the European

³¹ Loi n° 2015-1267 du 14 octobre 2015 relative au deuxième dividende numérique et à la poursuite de la modernisation de la télévision numérique terrestre.

level by Mr. Lamy and the Decision (EU) 2017/899 of the European Parliament and of the Council of May the 17th 2017, on the use of the 470-790 MHz frequency band in the European Union.

A10.2 800 MHz band. The Digital Dividend

A10.2.1 Introduction

From 2005 to 2011, French broadcasting progressively switched from analogue to digital, until the analogue TV switch off in November 2011. As DTT has allowed to multiplex TV programs on the same carrier, this was an opportunity to increase the number of broadcasted services, to improve image quality (by introducing HD in 2008) and to launch additional services, while freeing some spectrum to other services. Part of this spectrum was shared previously between Broadcasting regulator (Conseil supérieur de l'audiovisuel) and the Ministry of Defence.

Therefore, in December 2011, the regulator for the mobile operators, Autorité de Régulation des Communications Electroniques et des Postes (Arcep) published the results of the 2×30 MHz FDD auction, from the 800 MHz band, newly allocated to Mobile Services and previously used by analogue TV. Three Mobile Network Operators (MNOs) won 2×10 MHz and two 2×5 MHz blocks (B&C blocks on figure 1) were affected to the same MNO. Figure 16 indicates the 800 MHz Band Plan.

FIGURE 16

800 MHz auction Band Plan

791				821		832				862
10 MHz	5 MHz	5 MHz	10 MHz		10 MHz	5 MHz	5 MHz	10 MHz		
A	B	C	D		A	B	C	D		

A10.2.2 Sharing and coexistence at 800 MHz

The vast majority of reported interference cases that have been observed so far on fixed DTT reception were caused by LTE base station causing overload at DTT receiver due to active systems like amplifiers or DTT television / set-top box which means that all TV channels were interfered with.

A10.2.3 Summary of interference situation

During the period from 1st November 2012 to 13th October 2017, 34968 LTE Base Stations were put into service in the 800 MHz band and occurred 103 360 reported cases of interference to fixed rooftop DTT individual or collective receiving installations.

The number of interference cases per base station is very dependent on the local conditions of TV reception. In areas where the TV signal is weak, TV viewers are likely to have installed an amplifier and have a higher risk of being interfered with.

Cases of interference from the LTE Base Station onto DTT antenna are reported within an average and median distances equal to 0.72 km and 0.61 km respectively.

A10.2.4 Mitigation measures taken to address interference situations

Every interference case due to the deployment of LTE BS in the 800 MHz band onto the fixed roof-top DTT reception has been processed by adding a filter on the receiving side to handle overload interference due to LTE 800 MHz in-band emissions, either head-end filters – if active systems, like amplifiers are set between the roof-top antenna and the television /set-top box – or

user filters if not. The specifications of those filters have been defined by the administration, taking into account studies conducted with the help of stakeholders (broadcasters and the 800 MHz MNOs).

A10.2.5 Preliminary conclusions

In view of the information detailed above, almost all reported interference cases that have been observed so far on fixed roof-top DTT reception were caused by LTE base station causing DTT receiver overload due to active systems like amplifiers or DTT television / set-top box and all had been resolved by adding an LTE 800 MHz filter (either head-end filters or user filters). The average number of reported interference cases per deployed Base Station has reached a maximum (5.5) in March 2015 when around 10 000 were put into operation. In October 2017, after four years of deployment, 35 000 base stations are now in operation, the average number of interference cases per Base Station has reduced to 3 while MNOs are still deploying their networks. It has to be noted that interference cases may represent individual house or collective reception and, in that case, usually concerns more than one household.

Administration and operators have been able to handle successfully this kind of interference and a call-centre was created in order to inform victims of interference on the way forward.

A10.3 700 MHz band

A10.3.1 Introduction

On June 18th 2015, a Prime Minister's order settled the refarming of the 700 MHz band to Mobile Services between April the 5th 2016, and mid-2019.

To enable this reallocation, two national DTT multiplex were stopped and the entire DTT platform had to switch to the most efficient MPEG-4 coding standard (in terms of spectrum efficiency). The new usage of this standard allows the 32 national channels to be broadcasted within only 6 multiplexes with HD in mainland France.

The national operation to introduce MPEG-4 and to shut down the two multiplex took place during the night between April the 4th and the 5th 2016. This night also marked the beginning of the 700 MHz band refarming, starting by Region Île-de-France, including Paris, then, continuing area by area from October 2017 to June 2019, as shown on Fig. 17 noting that the date of the later stages (Phases 8, 9 and 10) are preliminary.

FIGURE 17

700 MHz refarming process

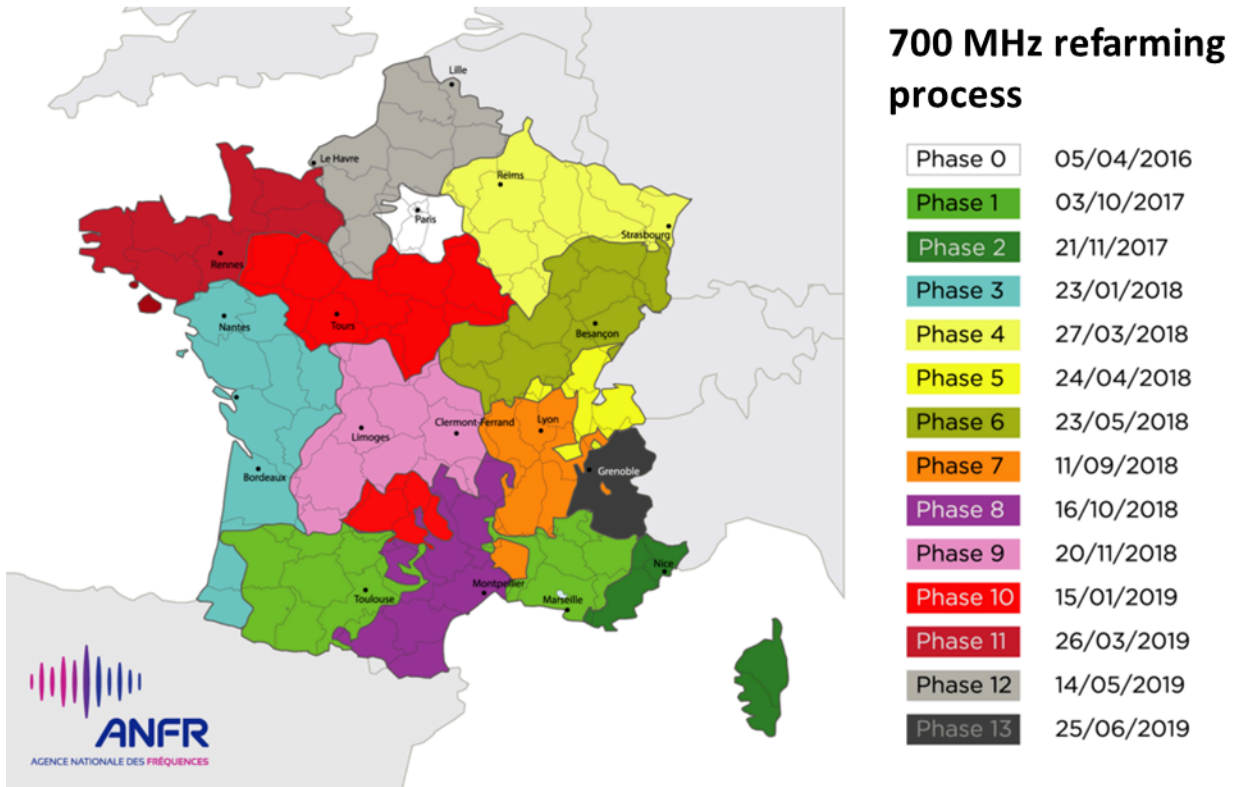

In parallel with the clearance process, Arcep launched auction in July 2015. The auction results were published in December 2015. The four MNO candidatures were validated and two MNOs won 2×10 MHz while the other two won 2×5 MHz as depicted in Fig. 18.

FIGURE 18

700 MHz Band Plan



A10.3.2 Sharing and coexistence at 700 MHz

As for the 800 MHz auction, the procedure for the 700 MHz band also included mitigation techniques to use the band and to collect and solve interference cases on DTT below 694 MHz, in coordination with the Agence nationale des fréquences (ANFR).

Based on 800 MHz band approach, administration and stakeholders have better knowledge on fixed roof-top TV receiving installations which could be interfered by LTE BSs.

Since LTE downlink is on the upper part of the band, the frequency separation between mobile downlinks and the highest DTT channel 48 is higher than at 800 MHz band, but the benefit on the DTT receiver overload with wide band amplifiers should be limited.

A10.3.3 Interference situation

As for the 800 MHz, filters have been designed to solve the interference issue on the DTT receiving site.

However, for the time being, mostly one MNO has launched base stations in the 700 MHz band and in majority in Region Ile-de-France due to refarming schedule. The other MNOs launched only few experimental base stations for the time being.

With around 1 000 base stations in operation to date (see Fig. 19) and only one MNO occupying the band, the statistics concerning interference cases are not yet relevant. With this preliminary feedback, it appears premature to draw conclusions on the importance of the interference issue at 700 MHz. However, as depicted by Fig. 20, other areas for the deployment of the LTE 700MHz base stations are (Phase 1) and will be (from Phase 2) opened from 2018 in France.

FIGURE 19

Agreement to put LTE base stations at 700 MHz into service

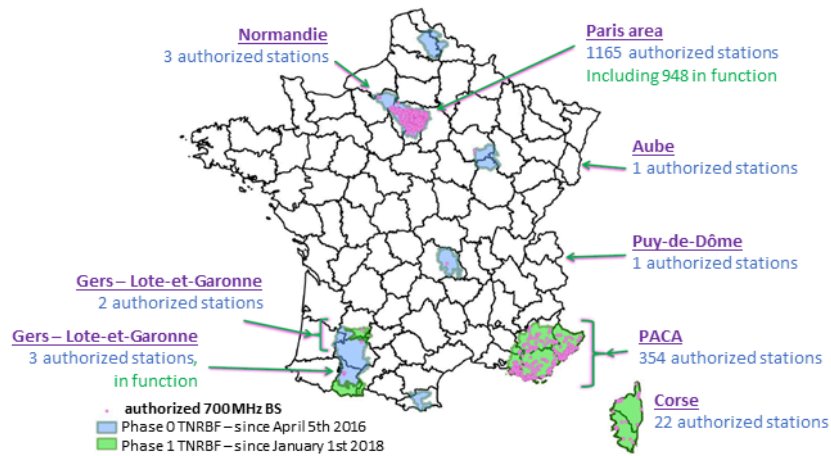

FIGURE 20

700 MHz base stations deployment plan in France (2018-2019)



A10.4 Conclusions

This contribution describes the way France introduced LTE in the second and third bands allocated to the Mobile Service below 1 GHz.

MNOs must declare every BS and their switch-on date to the ANFR. Based on this information, the ANFR can inform the concerned users about the potential risk of interference. Therefore, when people experience interference issues, they can join a call centre to know about the way to proceed (i.e. initiate a procedure to check if the interference is due to LTE 800, LTE 700 or another cause). If interference from LTE is proven, a technical operation on the DTT receiver must solve the case at the expense of the mobile operators.

The process has allowed introduction of LTE 800 and LTE 700, taking into account the incumbent services that can locally suffer from the compromises made during the compatibility studies.

Annex 11

Brazil:

Conclusion of the first stage of the Brazilian analogue television switch-off and the use of the 700 MHz band for IMT

A11.1 Introduction

When Brazil decided to implement Digital Terrestrial Television (DTV) in 2006, it was originally foreseen a 10-year period for the transition from analogue to digital television. In 2013, the Brazilian Administration started planning to accelerate this transition period with the goal to reorganize the digital television channels, making then possible to release the 700 MHz band for IMT. In 2014, an initial plan was established to perform the analogue television switch-off between 2015 and 2018 on a staggered process for the different regions in the country. This was followed by the re-planning of the television channels to release the 700 MHz band.

In September 2014, the 700 MHz band was auctioned to the mobile operators in Brazil, including the obligation that winning bidders would need to fund actions to ensure the successful completion of the digital switchover, such as: communication campaigns, distribution of DTV reception kits for low-income families, and household surveys to ensure that at least 90% of the affected households were able to receive DTV before the analogue switch-off. Furthermore, these funds were to be used for the digital TV channels repacking and the mitigation of possible interferences between the IMT services and broadcasting services in UHF band.

The first city to deploy a pilot analogue television switch-off was Rio Verde, in the state of Goiás. This pilot showed some of the challenges to be faced and provided insights before moving to a larger scale switch-off. As such, the Brazilian Administration started to discuss some changes in the process, in order to overcome the problems observed in reaching the goal of having at least 90% of the affected households ready for DTV reception before the analogue switch-off. The process was then divided in two stages: in the first stage (2016 to 2018) the analogue television switch-off would be performed in all the state capitals, metropolitan areas and other areas where it was required to release the 700 MHz band; on the second stage (up to 2023) the analogue television switch-off would be performed in the remaining cities of the country.

Furthermore, the budget coming from the 700 MHz auction would then be primarily used to accomplish the first stage, with more intensive communication campaigns and expanding the

population covered by the DTV reception kits distribution program. The broadcasters also needed to get more involved, intensifying their mandatory and voluntary communication campaigns, and promoting social mobilization initiatives. In 2018, Brazil has successfully completed the first stage of its analogue television switch-off.

A11.2 First stage results

During the first stage of its analogue television switch-off, from 2016 to 2018, 1 378 cities in 61 different clusters were impacted, accounting for the coverage of nearly 130 million people (63% of Brazil's population). More than 12 million DTV reception kits were distributed for low-income families. The analogue switch-off had no significant impact on the free-to-air terrestrial TV audience, an achievement particularly important to Brazil, as the vast majority of the population relies on free-to-air television. Therefore, they can continue relying on free-to-air broadcasting with improved quality and more content choices.

Other consequences of the digital switchover were a positive impact in the national industry (STBs, TVs, receiving antennas, Digital TV transmitters, transmission antennas etc.) and a renewed interest on free-to-air terrestrial television by the public. Furthermore, mobile services have been deployed using the 700 MHz band for IMT in more than 2 000 cities, improving the mobile broadband connectivity in Brazil.

Another relevant point to emphasize is that no interference on the Digital Television reception was detected since the beginning of the implementation of IMT services in the 700 MHz band.

A11.3 Next steps

Until mid-2019, there will still be some on-going TV channel repacking to release the 700 MHz band in the remaining parts of the country. There is also some ongoing work on interference mitigation, especially from the remaining analogue TV stations below 698 MHz into the IMT base stations uplink reception.

Regarding the second stage, the remaining 37% of the population (more than 77 million people) is distributed in other 4 192 cities in the country. After the implementation of Digital Terrestrial Television Brazil adopted an industrial policy that required that all flat-panel TVs manufactured from 2012 must have an integrated DTV receiver and from 2013 no more CRT TVs should be manufactured. As such, it is anticipated, based on the expected product lifetimes, that by 2023 Brazil would have nearly all TV sets in use already equipped with an integrated DTV receiver, thus facilitating the analogue television switch-off without the need for additional DTV reception kits distribution.

A11.4 Conclusion

Brazil is committed to the continuous development of free-to-air Digital Terrestrial Television as well as the expansion of mobile broadband in the country. This summary provides some additional information on the Brazilian analogue television switch-off that could assist other countries planning for such a process.

Annex 12

China: A national approach to terrestrial IMT deployment in 3 400-3 600 MHz band

A12.1 Introduction

The 3 400-3 600 MHz band has been identified for IMT since WRC-07. In China, it was used by Fixed Satellite Service on a primary basis for a long time. This band was planned for IMT-2020 in November 2017, and it was licensed for 5G trial in December 2018, and officially for commercial use in June 2019. Since 2019, two operators have deployed 5G in this band and have extensive experience in deploying and interference mitigation measures for this band in China.

A12.2 Frequency allocation of C band in China

To promote the development of 5G, MIIT issued the frequency plan for the IMT-2020 in November 2017:

- 3 300-3 600 MHz is planned for IMT-2020, where 3 300-3 400 MHz is only indoor in principle.
- No more new licenses for space service in the frequency band 3 400-3 700 MHz, including satellite TT&C frequencies in the frequency band 3 400-3 600 MHz.
- No more new licenses for FS frequency in 3 400-4 200 MHz.

China Telecom and China Unicom were respectively licensed to launch 5G trials in 3 400-3 500 MHz and 3 500-3 600 MHz in December 2018, and commercially launch 5G in June 2019.

FIGURE 21

Frequency allocation in the 3 300-4 200 MHz frequency band



A12.3 Sharing and coexistence in this band

A12.3.1 Summary of interference issues

There are intra-band and inter-band interferences between 5G station and FSS earth station. For inter-band frequency interference. It may need to consider IMT station emissions and LNA (low noise amplifier) / LNB (low noise block) overdrive, and the following lists the cause of each of them.

Interference from IMT base station emissions in adjacent band:

- Due to the very low power level of the incoming FSS signals, unwanted emissions generated by IMT base stations operating in an adjacent frequency band can cause interference to receiving FSS earth stations.

LNA/LNB overdrive:

- Earth station LNAs and LNBs are optimized for reception of very low power level of the incoming satellite signal and hence they are sensitive to interference from unwanted emissions.
- Incoming IMT signals at much higher power levels can severely affect the operating point of the LNA/LNB and drive it out of its dynamic range to where it exhibits a non-linear behaviour.

A12.3.2 Regulations

A12.3.2.1 Interference Coordination Regulation

In December 2018, MIIT issued the Interference Coordination Regulation between 5G stations and other radiocommunication stations in 3.0-4.2 GHz which took effects from 1st January 2019³².

- 1 Interference coordination areas from theoretical analysis are as below:
 - a) 3.4-3.6 GHz 5G outdoor systems v.s. 3.4-3.6 GHz FSS earth stations, coordinated separation distance 42.5 km.
 - b) 3.4-3.6 GHz 5G indoor systems v.s. 3.4-3.6 GHz FSS earth stations, coordinated separation distance 1 km.
 - c) 3.4-3.6 GHz 5G outdoor systems v.s. 3.6-3.7 GHz FSS earth stations, coordinated separation distance 4 km.
 - d) 3.4-3.6 GHz 5G indoor systems v.s. 3.6-3.7 GHz FSS earth stations, coordinated separation distance 50 m.
 - e) 3.4-3.6 GHz 5G outdoor systems v.s. 3.7-4.2 GHz FSS earth stations conforming with Annex 4 (adopting filtering and anti-saturation measures), coordinated separation distance 100 m.
 - f) 3.4-3.6 GHz 5G outdoor systems vs 3.7-4.2 GHz FSS earth stations not conforming with Annex 4, coordinated separation distance 2 km.
- 2 While the exact interference areas should be set based on the real geographical territory and the test.
- 3 Since 1st January 2019, no new licenses for satellite space radio stations and satellite earth stations in the frequency range of 3 400-3 700 MHz have been allowed. Except for the space radio stations and corresponding TT&C stations that approved and in development, or TT&C stations that in existing TT&C area and not imposing additional protection requirement to 5G systems.
- 4 Since 1st January 2019, for the newly installed satellite earth stations (including TT&C stations) in the 3 700-4 200 MHz and 4 500-4 800 MHz frequency bands, the technical specifications of their LNA or LNB shall conform with requirement in Interference Coordination Regulation Annex 4.

³² See Chinese Regulation at

https://www.miit.gov.cn/zwgk/zcwj/wjfb/qt/art/2020/art_f954a5f6fe8e42ea91beae0dff9af38d.html

A12.3.2.2 Interference Coordination Guide

In July 2019, MIIT issued the Interference Coordination Guide between 5G stations and FSS earth station in 3.0-5.0 GHz to promote the coordination and speed up 5G network deployment.

Some potential interference mitigation techniques can be applied:

- Change co-channel FSS receive frequency to other frequency bands.
- Improve the receive technique performance of LNA/LNB, such as adding additional filter.
- Install shielding net around the earth station.
- Avoid setting up 5G base stations in the main lobe of earth station antenna.
- Adjust the maximum radiation direction.
- Reduce the 5G maximum output power.
- Build separation between 5G base stations and FSS earth station.

A12.3.2.3 Regulation requirements for equipment in C-band

Improving the radio performance of 5G base stations and FSS earth stations is one of the most effective way to avoid interference.

In Interference Coordination Regulation Annex 4, the LNA/LNB in the 3 700-4 200 MHz frequency band should work in its dynamic range when the input power in 3 300-3 600 MHz is -20 dBm. It can be achieved by adding an additional filter before LNA/LNB.

And in June 2020, MIIT released the draft regulation, limits of unwanted emission power form 5G base station in the 3 400-3 600 MHz frequency band was required:

- Limits of unwanted emission power from 5G base station in 3 400-3 600 MHz is -26 dBm/MHz in 3 650-3 700 MHz.
- Limits of unwanted emission power from 5G station in 3 400-3 600 MHz is -47 dBm/MHz in 3 700-4 200 MHz.

A12.3.3 Interference mitigation measures

After lots of field tests, adding an additional filter between the LNA/LNB and feed is proved to be an effective way to avoid LNA/LNB overdrive problem, to protect the FSS earth station from harmful interference, and the service work normally. Depending on the antenna mode, one or two filters shall be needed.

FIGURE 22

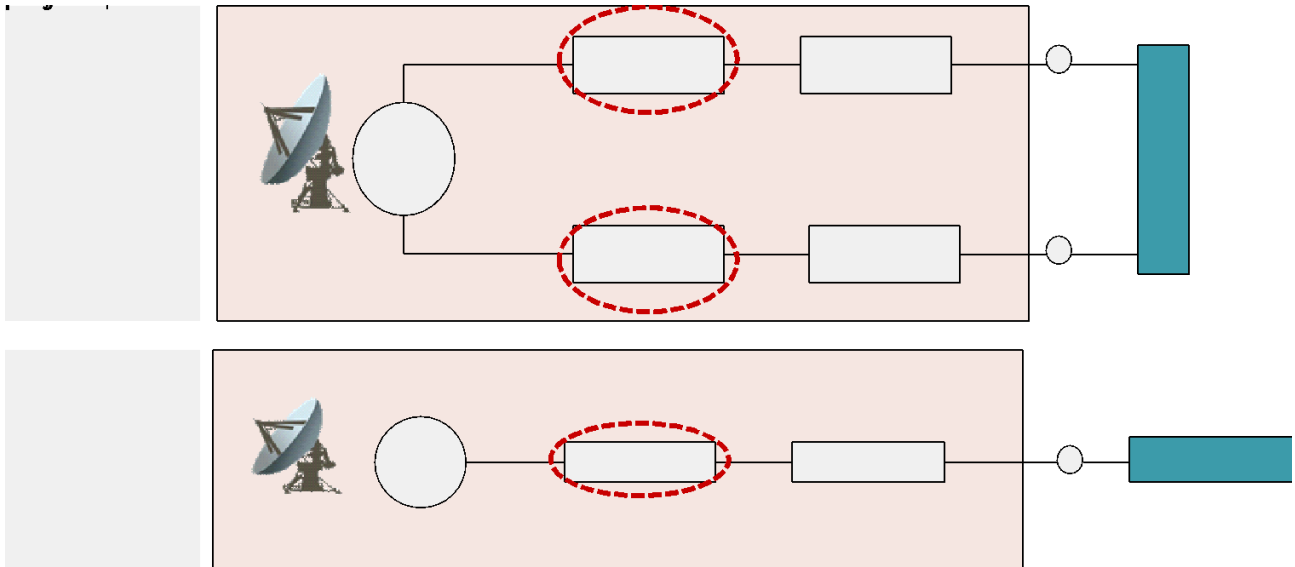
Interference mitigation method

Circular polarization antenna of Feed and LNA/LNB integration, it is unable to add the filter, maybe a new antenna is needed, or promote filter vendor to develop a new LNA/LNB integration with filter.

The filter index is confirmed after many discussions and validations, and is recommended as following:

- Input frequency: 3.4-4.2 GHz
- Output frequency: 3.7-4.2 GHz
- Insert loss: ≤ 0.5 dB in 3.7-4.2 GHz (tested in 23°C);
- VSWR ≤ 1.4 dB
- 5G signal suppression
 - ≥ 55 dB in 3.4-3.5 GHz
 - ≥ 55 dB in 3.5-3.6 GHz

According to these measures, more than 400 earth stations were reformed in China.

